

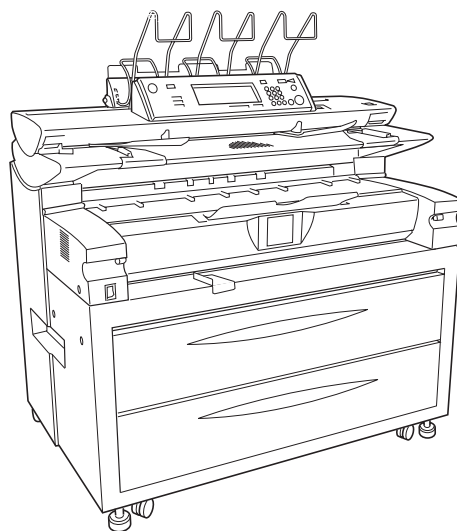

RICOH

AficioTM 470W

Operating Instructions Copy Reference



Read this manual carefully before you use this product and keep it handy for future reference.

For safety, please follow the instructions in this manual.



RICOH COMPANY, LTD.

15-5, Minami Aoyama 1-chome,
Minato-ku, Tokyo 107-8544, Japan
Phone: +81-(0)3-3479-3111

Overseas Affiliates

U.S.A.

RICOH CORPORATION
5 Dedrick Place
West Caldwell, New Jersey 07006
Phone: +1-973-882-2000

The Netherlands

RICOH EUROPE B.V.
Groenelaan 3, 1186 AA, Amstelveen
Phone: +31-(0)20-5474111

United Kingdom

RICOH UK LTD.
Ricoh House,
1 Plane Tree Crescent, Feltham,
Middlesex, TW13 7HG
Phone: +44-(0)20-8261-4000

Germany

RICOH DEUTSCHLAND GmbH
Mergenthalerallee 38-40,
65760 Eschborn
Phone: +49-(0)6196-9060

France

RICOH FRANCE S.A.
383, Avenue du Général de Gaulle
BP 307-92143 Clamart Cedex
Phone: +33-(0)-821-01-74-26

Spain

RICOH ESPAÑA S.A.
Avda. Litoral Mar, 12-14,
08005 Barcelona
Phone: +34-(0)93-295-7600

Italy

RICOH ITALIA SpA
Via della Metallurgia 12,
37139 Verona
Phone: +39-045-8181500

Hong Kong

RICOH HONG KONG LTD.
21/F., Tai Yau Building,
181, Johnston Road,
Wan Chai, Hong Kong
Phone: +852-2862-2888

Singapore

RICOH ASIA PACIFIC PTE.LTD.
260 Orchard Road,
#15-01/02 The Heeren,
Singapore 238855
Phone: +65-830-5888

Introduction

This manual contains detailed instructions on the operation and maintenance of this machine. To get maximum versatility from this machine all operators should carefully read and follow the instructions in this manual. Please keep this manual in a handy place near the machine.

Please read the Safety Information before using this machine. It contains important information related to USER SAFETY and PREVENTING EQUIPMENT PROBLEMS.



Notes

Some illustrations may be slightly different from your machine.

Certain options may not be available in some countries. For details, please contact your local dealer.



Warning:

Use of controls or adjustment or performance of procedures other than those specified in this manual might result in hazardous radiation exposure.

Notes:

Two kinds of size notation are employed in this manual. With this machine refer to the metric version.

For good copy quality, Ricoh recommends that you use genuine Ricoh toner.

Ricoh shall not be responsible for any damage or expense that might result from the use of parts other than genuine Ricoh parts in your Ricoh office product.

Power Source

120V, 60Hz, 20A or more

Please be sure to connect the power cord to a power source as above. For details about power source, see P.147 "*Power Connection*".

Safety Information

When using your equipment, the following safety precautions should always be followed.

Safety During Operation

In this manual, the following important symbols are used:

⚠ WARNING:
Indicates a potentially hazardous situation which, if instructions are not followed, could result in death or serious injury.

⚠ CAUTION:
Indicates a potentially hazardous situation which, if instructions are not followed, may result in minor or moderate injury or damage to property.

⚠ WARNING:

- **Connect the power cord directly into a wall outlet and never use an extension cord.**
- **Disconnect the power plug (by pulling the plug, not the cable) if the power cable or plug becomes frayed or otherwise damaged.**
- **To avoid hazardous electric shock or laser radiation exposure, do not remove any covers or screws other than those specified in this manual.**
- **Turn off the power and disconnect the power plug (by pulling the plug, not the cable) if any of the following conditions exists:**
 - **You spill something into the equipment.**
 - **You suspect that your equipment needs service or repair.**
 - **Your equipment's cover has been damaged.**
- **Do not incinerate spilled toner or used toner. Toner dust might ignite when exposed to an open flame.**
- **Disposal can take place at our authorized dealer or at appropriate collection sites.**
- **Dispose of the used toner cartridge in accordance with the local regulation.**

⚠ CAUTION:

- *Protect the equipment from dampness or wet weather, such as rain, snow, and so on.*
- *Unplug the power cord from the wall outlet before you move the equipment. While moving the equipment, you should take care that the power cord will not be damaged under the equipment.*
- *When you disconnect the power plug from the wall outlet, always pull the plug (not the cable).*
- *Do not allow paper clips, staples, or other small metallic objects to fall inside the equipment.*
- *Keep toner (used or unused) and toner bottle out of the reach of children.*
- *For environmental reasons, do not dispose of the equipment or expended supply waste at household waste collection points. Disposal can take place at an authorized dealer or at appropriate collection sites.*
- *The inside of the machine could be very hot. Do not touch the parts with a label indicating the "hot surface". Otherwise it could cause a personal burn.*
- *Our products are engineered to meet high standards of quality and functionality, and we recommend that you only use the expendable supplies available at an authorized dealer.*

Warnings and Precautions

This manual uses the following warning and precaution symbols to indicate important safety information.

When adding paper or clearing paper jams, be careful not to burn or injure yourself.

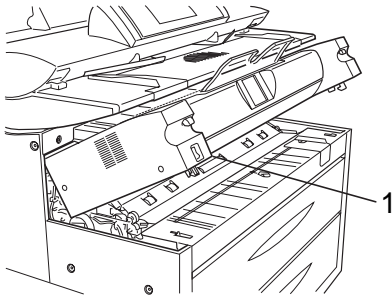

ZEDH280E

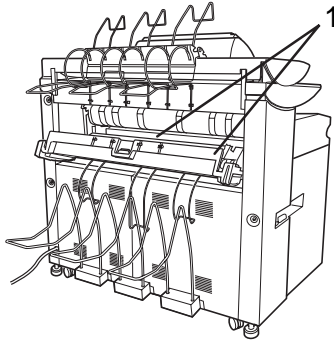

ZEDH290E

1 Hot Surface Warning

	CAUTION ACHTUNG ATTENTION ATTENZIONE PRECAUCIÓN	HOT SURFACE AVOID CONTACT HEISSE OBERFLÄCHE NICHT BERÜHREN SURFACE TRES CHAUDE NE PAS TOUCHER SUPERFICIE CALDA NON TOCCARE NO TOCAR, ALTA TEMPERATURA	VARNING PAS OP ADVARSEL ADVARSEL 高温注意	HET YTA RÖR INTE OPPERVLAKTE HEET! NIET AANRAKEN VARM OVERFLATE UNNGÅ BERØRING VARM OVERFLADE UNDGÅ BERØRING
--	--	--	--	---

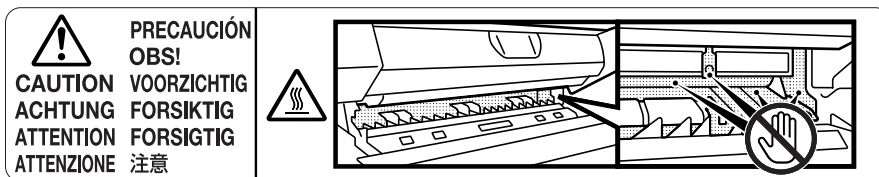

This symbol indicates that you should take care not to touch a hot surface. The fusing unit becomes hot. Be careful not to touch this area when clearing paper jams.

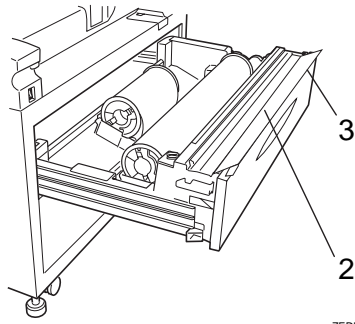

ZEDH300E

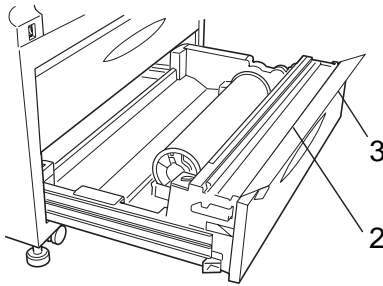

ZEDH310E

2 Cutter Blade Warning

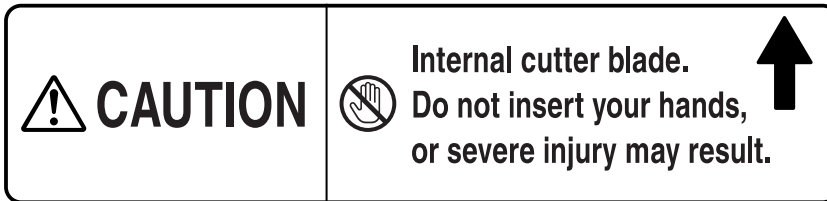

This label indicates that there is a cutter blade inside, and you should be careful not to touch this area with your fingers or hands. Be careful not to touch this area when adding paper.

3 Feed Roller Warning Label

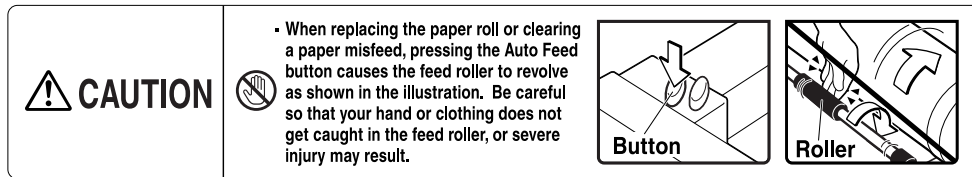

This label indicates that you should be careful not get your fingers or cloths caught in the feed roller. When replacing the paper roll, or clearing paper jams in the paper feed area, be careful so that your hand or clothing does not get caught in the feed roller.

How to Read this Manual

Symbols

In this manual, the following symbols are used:

WARNING:

This symbol indicates a potentially hazardous situation that might result in death or serious injury when you misuse the machine without following the instructions under this symbol. Be sure to read the instructions, all of which are described in the Safety Information section.

CAUTION:

This symbol indicates a potentially hazardous situation that might result in minor or moderate injury or property damage that does not involve personal injury when you misuse the machine without following the instructions under this symbol. Be sure to read the instructions, all of which are described in the Safety Information section.

* The statements above are notes for your safety.

Important

If this instruction is not followed, paper might be misfed, originals might be damaged, or data might be lost. Be sure to read this.

Preparation

This symbol indicates the prior knowledge or preparations required before operating.

Note

This symbol indicates precautions for operation, or actions to take after misoperation.

Limitation

This symbol indicates numerical limits, functions that cannot be used together, or conditions in which a particular function cannot be used.

Reference

This symbol indicates a reference.

[]

Keys that appear on the machine's panel display.

[]

Keys built into the machine's operation panel.

Terms in this Manual

Guide To Option Components

In this manual, the following abbreviations are used.

- Roll Holder Unit Type A → Roll holder
- 2nd Roll Tray Type A → Lower tray
- Stamp Board Type A → Stamp board
- Original Tray Type G → Original Tray
- Hard Disk Drive Option Type 470 → HDD

Terms

- Long length original/paper
Original/paper length longer than 1,189mm, 44".

Key Names

In the screen and panel display, the following abbreviations are used.

- Direct Size Magnification → D. Size Mag.
- Hard Tone → H.T.
- Horizontal → Horiz.
- Magnification → Mag.
- Original → Orig.
- Preview → Prev.
- Reduce/Enlarge → R/E
- Vertical → Vert.

What You Can Do With This Machine (Copy Mode)

Selecting Original Type Setting
⇒ Page XXX

- Text
- Photo
- Text/Photo
- Pale
- Special Orig.
- Blue Erase
- Patched Orig.
- Photo (Hard Tone)
- Generation

Selecting Copy Paper
⇒ Page XXX

Auto Reduce/Enlarge
⇒ Page XXX

Adjusting Copy Image Density
⇒ Page XXX

Switching the Original Exit
⇒ Page XXX

Switching the Copy Exit
⇒ Page XXX

Setting the Length of Copy Paper Cut

- Synchro Cut ⇒ Page XXX
- Preset Cut ⇒ Page XXX
- Variable Cut ⇒ Page XXX

Edit Image

Stamp (Optional stamp board and HDD(harddisk) are required)

- Background Numbering ⇒ Page XXX
- User Stamp ⇒ Page XXX
- Page Numbering ⇒ Page XXX
- Date Stamp ⇒ Page XXX
- Preset Stamp ⇒ Page XXX
- User Stamp Repeat ⇒ Page XXX
- Preset Stamps: COPY, URGENT, CONFIDENTIAL, PRIORITY, For Your Info., PRELIMINARY, For Internal Use Only

Image Overlay ⇒ Page XXX

Format Overlay ⇒ Page XXX

Positive/Negative ⇒ Page XXX

Mirror Image ⇒ Page XXX

Image Repeat ⇒ Page XXX

Double Copies ⇒ Page XXX

Sort ⇒ Page XXX

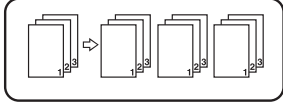

Rotate Sort ⇒ Page XXX

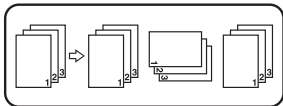

Sample Copy ⇒ Page XXX

Partial Copy ⇒ Page XXX

Shift/Erase

Shift ⇒ Page XXX

Top

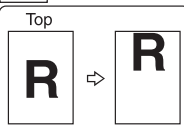

Bottom

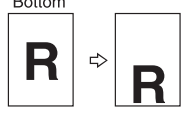

Left



Right

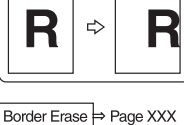

Margin Adjustment ⇒ Page XXX

Top(+)

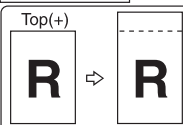

Top(-)

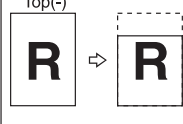

Bottom(+)



Bottom(-)



Border Erase ⇒ Page XXX

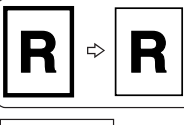

Delete Inside ⇒ Page XXX

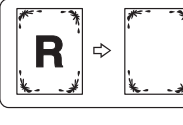

Delete Outside ⇒ Page XXX



Reduce/Enlarge

Preset Reduce/Enlarge ⇒ Page XXX

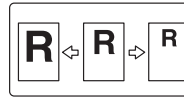

Directional Magnification(%) ⇒ Page XXX

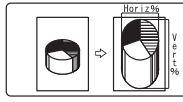

Zoom ⇒ Page XXX



Directional Size Magnification(inch) ⇒ Page XXX

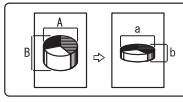

Size Magnification ⇒ Page XXX

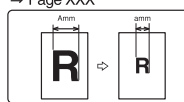

Fine Magnification ⇒ Page XXX



DOLPHIN001

You can combine the various machine functions to make fast, beautiful copies that best suite the conditions, type of original, and paper you are using.

❖ **Make copies from existing copies ⇒ Generation**

To make copies from existing copies, select **[Generation]** in the **[Special Orig.]** settings. You can also use the Noise Reduction function in the **[Generation]** settings to remove any dirt or stains in the white margins of the original copy. You can adjust the setting to low or high (The default setting is normal). See P.40 *“Selecting Original Type Setting”*

❖ **Increase the image quality to match that of the original ⇒ Selecting Original Type Setting**

You can select various settings for the type of original you are using, such as Text, Text/Photo, Photo, Pale, and Special Original, to improve the quality of your copies. For example, for Text mode the edges are sharp, for Photo mode the image is processed so that the copy looks like a glossy photo. See P.40 *“Selecting Original Type Setting”*

❖ **Check the current copy settings ⇒ Sample Copy**

You can make a copy of the first part (0 – 250mm (0 – 9.8")) of an original up to a length of 210mm (8.3"). You can use the Dark, Light and other settings to adjust the quality of the copy. See P.56 *“Sample Copy”*

❖ **Copying only part of the original ⇒ Partial Copy**

You can choose to copy only the part of original you specify. See P.57 *“Partial Copy”*

❖ **Overlay several originals into one copy ⇒ Image Overlay, Format Overlay**

You can combine two originals on to one copy (Image Overlay), or store an image to use as a background and overlay it with the scanned original. See P.81 *“Image Overlay”* P.83 *“Format Overlay”*

❖ **Increase the number of copies after making a copy ⇒ Restart Copy**

If after making five copies you realize you need to make an additional three copies, there is no need to place the original. Just enter the number of additional copies and then press the **[Start]** key again. If the machine runs out of paper during copying, you can also press the **[Start]** key again after loading more paper. See P.35 *“Restart Copy”*

❖ **Adjust the Fine Magnification (-1.0 – +1.0%) settings, after making a copy ⇒ Additional Copy**

When copying on to film etc., you can use the Fine Magnification (-1.0 – +1.0%) setting to change the horizontal or vertical size of the image if it does not match the size of the media. You can also adjust the settings if you want to copy a scanned original on to translucent paper (tellum) after making copies on plain paper. See P.36 *“Additional Copy”*

- ❖ **Adjust the horizontal or vertical size to allow for paper expansion ⇒ Fine Magnification**
 When using types of paper that expand when exposed to high temperatures or humidity, the size of the original and copy may be different. In these cases, you can adjust the horizontal and vertical magnification ratio for each paper type. Once you have set the magnification ratio for a paper type, the setting is used whenever that paper type is used (To cancel the setting, change the setting to 0.0%). See P.61 *"Fine Magnification"*
- ❖ **Copy to the same length ⇒ Preset Cut/Variable Cut**
 You can copy originals of varying lengths to copies that are all the same length. This is useful for filing. See P.49 *"Preset Cut"*, P.50 *"Variable Cut"*
- ❖ **Store long length originals ⇒ Document Roller**
 You can store long length originals while rolling them. See P.22 *"Switching the Original Exit"*
- ❖ **Count the number of originals in one job ⇒ Original Count/Reset**
 When copying a set of originals, you can use the Original Counter function to check that none of the originals have been skipped or misfed. The counter is reset for the next job. See P.29 *"Original Counter/Reset"*
- ❖ **Copy on to cut sheet paper ⇒ Copying From The Bypass Tray**
 You can use the bypass tray to copy on to cut sheet paper or special sized paper. See P.46 *"Copying from the Bypass Tray"*
- ❖ **Make a copy during another copy job ⇒ Interrupt Copy**
 You can interrupt a copy job to make urgent copies, even if that job uses the sorter or is a continuous copy job. See P.39 *"Interrupt Copy"*
- ❖ **Reserve the next copy job and scan the originals ⇒ Job Preset**
 While the machine is copying (printing) another copy job, you can select the settings for the next copy job and scan the originals (Depending on the functions used in the current copy job (Such as Image Overlay), you may not be able to preset the next job). See P.37 *"Job Preset"*
- ❖ **Store settings so they can be reused to match the originals or type of job ⇒ Programs**
 You can store settings, such as the density or magnification ratio, in a program so that they can be called up when necessary for another job. This means you do not need to reset the same settings again. You can store up to 20 programs. See P.53 *"Program"*
- ❖ **Change the selected paper roll when the [Clear Modes/Energy Saver] key is pressed**
 When the power is turned on, after Auto Reset, or the [Clear Modes/Energy Saver] key has been pressed, if the paper of the same width is loaded, you can change the selected paper roll. See P.127 *"Paper Roll Priority"*

❖ **Change the selected setting (function) when the [Clear Modes/Energy Saver] key is pressed**

When the power is turned on, after Auto Reset, or the [**Clear Modes/Energy Saver**] key has been pressed, you can change the density, paper cut method, and other function settings that are selected on the screen. To use this function, the settings you want to use must already be stored in program 20. You must also select Program No.20 for the Initial Mode Set settings in User Tools (Copier Features).

This way, you can call up settings you frequently use at any time. Program No.20 is a special mode that can change the initial mode settings. See P.126 *“Initial Mode Set”*

TABLE OF CONTENTS

Guide to Components	1
Options	5
Operation Panel	6
Panel Screen	8
Displays And Key Operations	8

1. Basics

Starting The Machine	11
Turning On the Main Power	11
Turning On the Power	11
Turning Off the Power	12
Turning Off the Main Power	12
Anti-humidity Heater Switch	12
Originals	13
Sizes and Weights	13
Missing Image Area	15
Copy Paper	16
Recommended Size and Type	16
Toner	20
Handling	20
Storage	20
Usage	20



2. Copying

Before Copying	21
Switching the Original Exit	22
Adjusting The Original Tray (Option)	25
Switching the Copy Exit	25
Basic Procedure	28
Original Counter/Reset	29
Auto Reset	30
Auto Off	30
Setting Originals	31
Setting Carrier Sheet	32
Repeat Copy	34
Restart Copy	35
Additional Copy	36
Job Preset	37
Interrupt Copy	39

Basic Functions	40
Selecting Original Type Setting	40
Adjusting Copy Image Density	41
Selecting Copy Paper	42
Auto Reduce/Enlarge	43
User Auto Reduce/Enlarge	44
Copying from the Bypass Tray	46
Setting the Length of Copy Paper Cut	48
Synchro Cut	48
Preset Cut	49
Variable Cut	50
Sort/Rotate Sort	51
Program	53
Storing Your Settings	53
Deleting a Program	54
Recalling a Program.....	54
Other Functions	55
Energy Saver Mode	55
Auto Start	55
User Codes	55
Sample Copy	56
Partial Copy	57
Preset Reduce/Enlarge	58
Zoom	59
Fine Magnification	61
Size Magnification	63
Directional Magnification (%)	64
Directional Size Magnification (inch)	66
Margin Adjustment	68
Shift	70
Border Erase	72
Delete Inside	74
Delete Outside	76
Double Copies	77
Image Repeat	78
Positive/Negative	79
Mirror Image	80
Image Overlay	81
Image Overlay Limitations.....	82

Format Overlay	83
Program/Delete, Overlay Format	84
Background Numbering.....	86
User Stamp Repeat.....	87
Preset Stamp.....	88
User Stamp.....	90
Program/Delete, User Stamp	91
Date Stamp.....	94
Page Numbering.....	96
Combination Chart	98
Chart of Scan Sizes for Each Function	101

3. Troubleshooting

If Your Machine Does Not Operate As You Want	103
Error Messages.....	103
Screen.....	105
If You Cannot Make Clear Copies	106
If You Cannot Make Copies As You Want	109
Changing The Roll Paper Size.....	111
Removing the Roll Paper Holder.....	111
Setting the Roll Paper Holder.....	112
 Loading Roll Paper.....	113
 Adding Toner	115
 Clearing Misfeeds.....	117
Original Misfeeds	117
Paper Misfeeds	118

4. User Tools (Copier Features)

Accessing The User Tools (Copier Features).....	123
Exiting from User Tools.....	124
User Tools Menu (Copier Features).....	125
Settings You Can Change with the User Tools	126
General Features 1/2	126
General Features 2/2	128
Reproduction Ratio	131
Adjust Image	133
Stamp 1/2.....	134
Stamp 2/2.....	138
Key Operator Tools.....	140

5. Remarks

Do's and Don'ts	143
Where To Put Your Machine	145
Machine Environment	145
Access To Machine.....	146
Power Connection.....	147
Disposal	147
Maintaining Your Machine	148
Cleaning inside the Original Cover.....	148
Cleaning The Paper Path Section.....	149

6. Specification

Mainframe	151
Options	156
Settings Record Sheet	157
Magnification Ratio Chart.....	160
Measure Chart	161
INDEX	162

Guide to Components

◆ Front

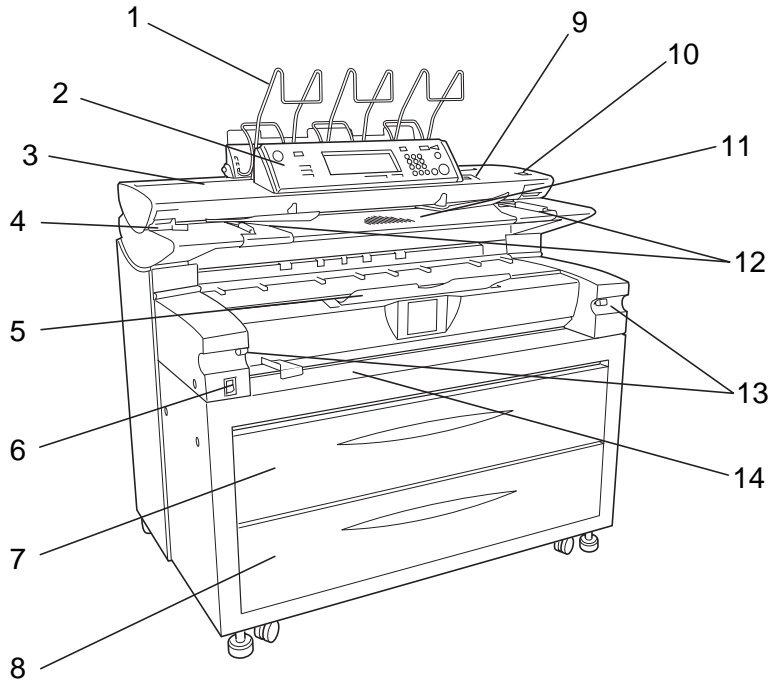

ZEDH320E

1. Original output (upper)

When original output (upper) is selected, the originals are stacked here after they have been scanned.

2. Operation panel

This is used to set function settings, and the indicator indicators indicate the status of the machine. See P.6 "Operation Panel"

3. Original cover

This protects the original feed mechanism and the exposure glass.

4. Original cover release lever

Use this lever to open the original cover to clear original jams or for cleaning.

5. Front output auxiliary tray

Receiving copy paper output, this is used to load originals on rolled paper too.

6. Main power switch

Use this turn the main power on or off. If you will not be using the machine, disconnect the power cord. Normally the machine should be left on.

7. Upper tray

This stores paper roll 1 (front) and paper roll 2 (rear).

8. Lower tray (option)

This stores paper roll 3.

9. Operation switch

Use this to turn the power on or off. The power indicator is lit when the power is on.

10. **[Scanner Stop]** key

Use this key if originals are fed at a slant, or if you want to cancel scanning while an original is being fed into the machine. You can also use this to release the paper edge hold function.

11. Original table

Place your originals here.

12. Original guide

Set this to the width of your originals.

13. Paper Path Section Release Lever

Use this lever to open the paper path section to clear paper jams or cleaning.

⚠ Important

- ❑ Do not leave the paper path section left open for more than 10 minutes.

14. Bypass tray

Use this tray to make manual feed copies.

❖ Rear

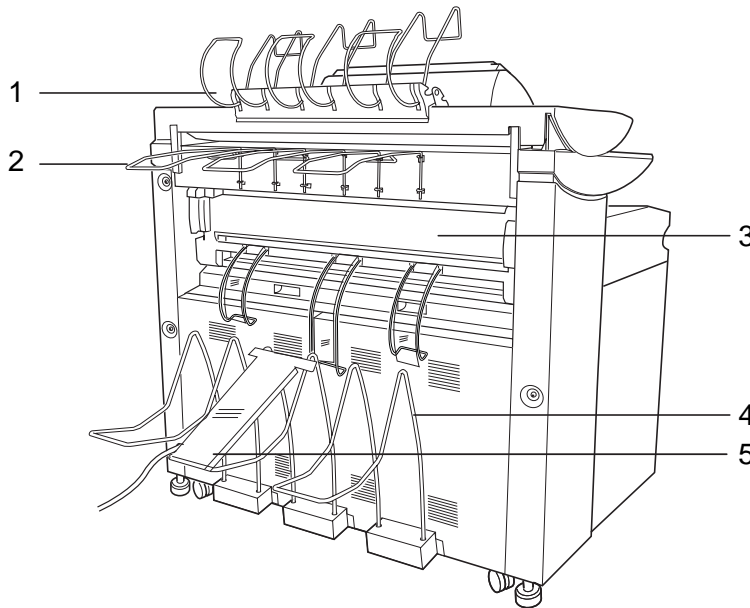

ZEDH330E

1. Document roller

This stores long length originals on rolled long paper after they have been fed through the machine. See P.22 "*Switching the Original Exit*"

2. Original output (Rear (Straight))

This holds originals that are ejected at the back of the machine. See P.22 "*Switching the Original Exit*"

3. Fusing unit cover

This protects the fusing unit.

4. Copy output (Rear)

This stores copies output to the rear of the machine.

5. Copy output (Rear) auxiliary guide

This prevents paper from getting caught in the rear of the copy output (rear) sticker, when feeding A0 size (E size) paper from the rear of the machine. See P.26 "*Using rear output for A0 (E) Paper*"

❖ Upper Tray

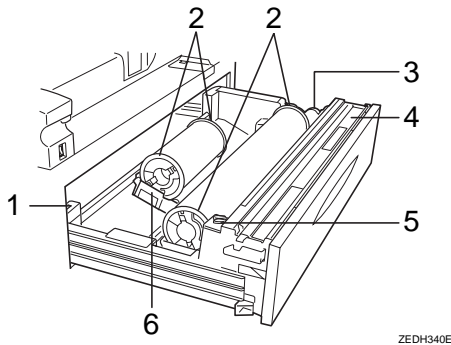

1. Anti-humidity heater switch

When humidity is high, the paper in the paper roll tray may absorb moisture, which can effect the image quality of your copies. The anti-humidity heater prevents this. Turn this switch to on when the humidity is high. See P.12 “*Anti-humidity Heater Switch*”

2. Roll holder

The two roll holders hold the roll paper and are mounted on the roll paper holder on the paper roll tray.

3. Paper feed knob

Use this when loading paper rolls, or to clear paper jams. See P.113 “*Loading Roll Paper*”, P.117 “*Clearing Misfeeds*”

4. Cutter knob

Use this to manually cut paper if there are paper jams in the cutter area of the machine. Always return the cutter knob to the left or right side.

5. Auto feed button

Use this to clear misfeeds in the paper feed area, when roll paper is loaded. Keep this button pressed to feed the roll paper continuously. If approximately 100mm, 3.9" of paper is released, it will be cut automatically. See P.113 “*Loading Roll Paper*”, P.117 “*Clearing Misfeeds*”

6. Roll paper holder

Adjust this to the size of the paper roll you are using. See P.111 “*Changing The Roll Paper Size*”

❖ Lower Tray (option)

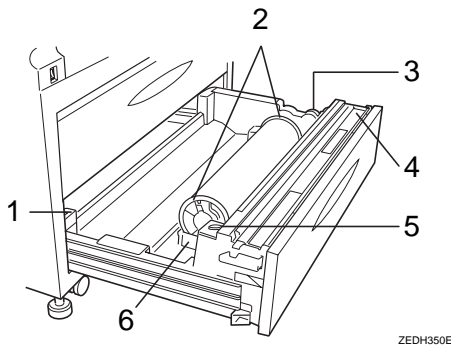

1. Anti-humidity heater switch

When humidity is high, the paper in the paper roll tray may absorb moisture, which can effect the image quality of your copies. The anti-humidity heater prevents this. Turn this switch to on when the humidity is high. See P.12 “*Anti-humidity Heater Switch*”

2. Roll holder

The two roll holders hold the roll paper and are mounted on the roll paper holder on the paper roll tray.

3. Paper feed knob

Use this when loading paper rolls, or to clear paper jams. See P.113 “*Loading Roll Paper*”, P.117 “*Clearing Misfeeds*”

4. Cutter knob

Use this to manually cut paper if there are paper jams in the cutter area of the machine. Always return the cutter knob to the left or right side.

5. Auto feed button

Use this to clear misfeeds in the paper feed area, when roll paper is loaded. Keep this button pressed to feed the roll continuously. If approximately 100mm, 3.9" of paper is released, it will be cut automatically. See P.113 “*Loading Roll Paper*”, P.117 “*Clearing Misfeeds*”

6. Roll paper holder

Adjust this to the size of the paper roll you are using. See P.111 “*Changing The Roll Paper Size*”

Options

❖ **Lower tray**

Adds the lower tray (paper roll 3).

❖ **Stamp board**

This adds the "Background Numbering", "User Stamp Repeat", "Preset Stamp", "User Stamp", "Date Stamp" and "Page Numbering" functions to the machine.

❖ **Roll holder**

Use this to set one paper roll in the roll paper holder on the paper trays.

This is useful when you need to quickly change to a different size roll paper from the roll holder.

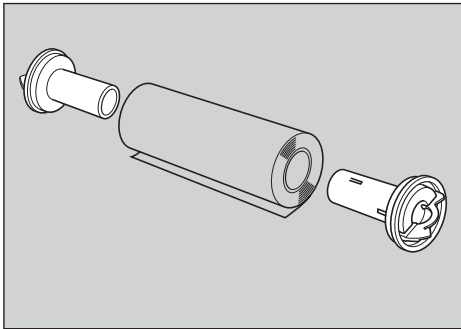

❖ **HDD**

Allows you to increase the copy functions, like the following:

- Repeat Copy (longer than A0(E) □)
- Stamp function (required stamp board)
- Sort/Rotate Sort (50 sheets or more)
- Restart Copy (longer than A0(E))
- Format Overlay
- Sample Copy (longer than A0(E))

❖ **Original tray**

This can stack originals that consist of many sheets.

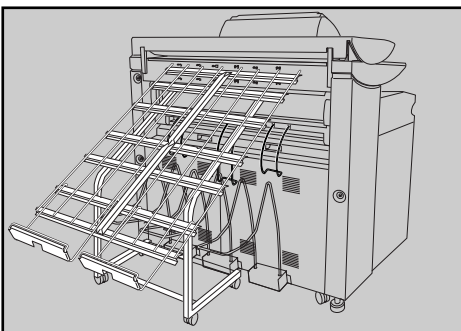

Operation Panel

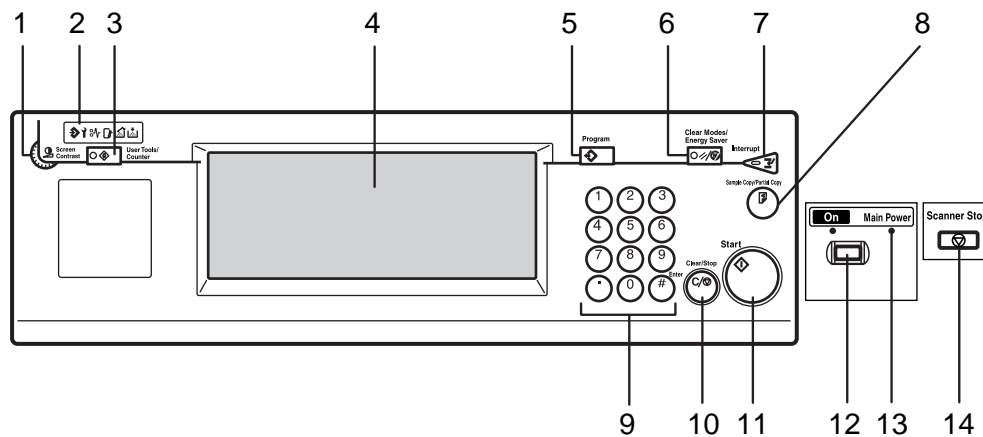

ZEDH361E

1. Screen contrast knob

Adjusts the brightness of the screen.

2. Indicators

These indicators show errors or the status of the machine. See P.103 "Troubleshooting"

3. [User Tools/Counter] key

Press this key to change the default settings and operation conditions to match your requirements. Also displays the total number of copies made. See P.123 "User Tools (Copier Features)"

4. Screen

Shows operation status, error messages, and function menus. See P.8 "Panel Screen"

5. [Program] key

Press to select the program mode. See P.53 "Program"

6. [Clear Modes/Energy Saver] key

Clears the contents of a setting. Also, if pressed for more than one second, the machine is switched to Energy Saver mode. See P.55 "Energy Saver Mode"

7. [Interrupt] key

Press to make interrupt copies during a copy run. See P.39 "Interrupt Copy"

8. [Sample Copy/Partial Copy] key

Allows you to make a Sample Copy (using the current settings) or Partial Copy (copies a specified part of an original) to check the settings before making full copies. See P.56 "Sample Copy", P.57 "Partial Copy"

9. Number keys

Use to enter the desired number of copies and data for selected modes. Use the Enter key to enter data in selected modes.

Press the [#] key to confirm the values you have entered.

Press the [.] key to enter a decimal point.

10. [Clear/Stop] key

Use this key to clear numbers you have entered, or to interrupt or cancel a copy job.

11. **[Start]** key

Press to start copying. The default setting is for the originals to be scanned first, and then copied. You can also use this key to resume an interrupted copy job (Restart Copy) or repeat a copy job (Repeat Copy). See P.128 "*Print Start Trigger*"

12. **Operation Switch**

Use this to turn the power on or off. The power indicator is lit when the power is on. See P.11 "*Starting The Machine*"

13. **Main power indicator**

Light up when the main power switch is set to on.

14. **[Scanner Stop]** key

Press this key if originals are fed at a slant, or if you want to cancel scanning while an original is being fed into the machine.

You can also use this to release the paper edge hold function.

Note

- If **[Rear: Edge Hold]** is selected for "Original Output Tray" in System Settings, when the originals are output to the rear of the machine, the originals are held after they have been scanned. You can use the **[Scanner Stop]** key to release this paper edge hold function.
- You can change the original output tray setting in User Tools. See "Original Output Tray" in the Systems Settings manual.

Reference

⇒ P.117 "*Original Misfeeds*"



Panel Screen

The screen and panel display shows operational status, error messages, and function menus.

Important

- ❑ Do not apply a strong shock or force of about 30N (about 3kgf) or more to the screen. Otherwise, the screen might be damaged.

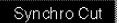
Note

- ❑ The function items displayed serve as selector keys. You can select or specify an item by lightly pressing it.
- ❑ When you select or specify an item on the screen, it is highlighted like .
- ❑ Keys appearing as  cannot be used.

Displays And Key Operations

Copy Initial Display

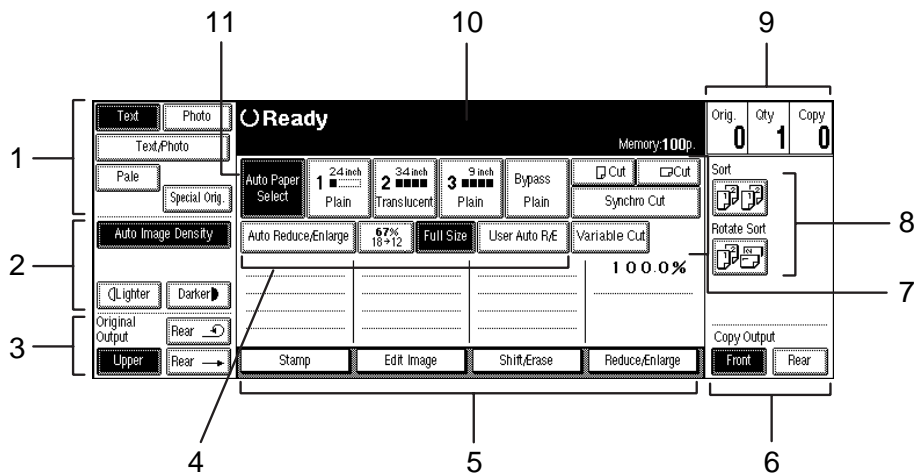

ZEDH371E

1. Selecting Original Type Setting

Selects the type of original, such as Text, Photo, Pale. By selecting the original type, you can ensure that you get excellent copy results. See P.40 "Selecting Original Type Setting"

2. Adjusting Copy Image Density

The image density is adjusted using Auto Image Density (automatically adjusting the image density), or by applying one of the density level settings to the image of the original. You can also adjust the density for the image only. See P.41 "Adjusting Copy Image Density"

3. Original Output Location

Select the original output location from **[Upper]**, **[Rear Straight]** or **[Rear (Document Roller)]**. See P.22 *“Switching the Original Exit”*

4. Basic Reduce/Enlarge

Here you can select basic reduction and enlargement ratios by pressing the keys. See P.43 *“Auto Reduce/Enlarge”*, P.44 *“User Auto Reduce/Enlarge”*

5. Functions

Here you can make the basic settings for Edit Image, Shift/Erase, Reduce/Enlarge and Stamp. The settings for each function are displayed in each function key. The stamp key is displayed when the optional stamp board has been installed.

Reference

For details, see explanations of each function.

6. Copy Output Location

Select a copy output location from Front or Rear. See P.25 *“Switching the Copy Exit”*

7. Paper Cut Direction

Specifies the direction for cutting roll paper, as well as the length and mode. See P.48 *“Setting the Length of Copy Paper Cut”*

8. Sorting

Allows you to arrange copies in sets (Sort), or change the direction of the sets (Rotate Sort). See P.51 *“Sort/Rotate Sort”*

9. Original/Sets/Copy Totals

Displays the number of originals scanned into memory, the number of sets, and the number of copies. Pressing **[Orig.]**, resets the original count to 0. See P.29 *“Original Counter/Reset”*

10. Settings Status

Displays messages, etc., describing the status of various settings. See P.128 *“Memory Status Display”*

11. Selecting Copy Paper

Selects the paper rolls, or bypass tray, to be used for copies. See P.42 *“Selecting Copy Paper”*

1. Basics

Starting The Machine

To start using the machine, press the main power switch or the operation switch to turn the machine on.

Preparation

If you will not be using the machine for a long time, turn the main power switch off. For example, turn the switch off before holidays. Otherwise, turn the operation switch off and on to use the machine.

Turning On the Main Power

1 Make sure that the power plug is firmly inserted into the wall outlet.

2 Turn the main power switch on.

The power indicator lights up when the power comes on.

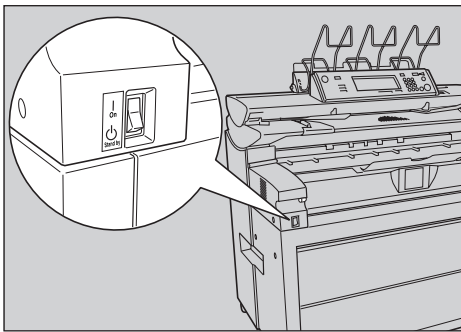

Turning On the Power

1 Press the operation switch, and the power indicator lights up.

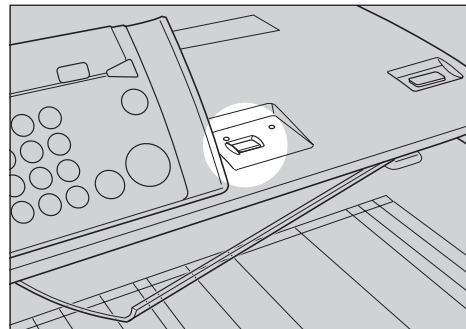

Note

- If the machine does not start even when the operation switch is pressed, check that the main power switch is in the On position.
- The machine can be used about two minutes after it has been switched on.
- Immediately after the machine is turned on, or if the temperature is low, or if making a lot of continuous copies (more than 30 sheets/A0, or more than 30 sheets/E size), the continuous copy speed may be reduced to ensure the toner fuses to the paper.
- The machine automatically enters Energy Saver mode or turns itself off if you do not use it for a while. See Panel Off Timer, Energy Saver Timer, and Auto Off Timer in the Systems Settings manual.

1

Turning Off the Power

Preparation

Press the operation switch to turn the power off, if you will not be using the machine for a while.

Limitation

- ❑ You cannot turn the machine off while the message "NOW LOADING" is displayed on the screen by pressing the operation switch.

- 1 Press the operation switch, the power indicator goes out.

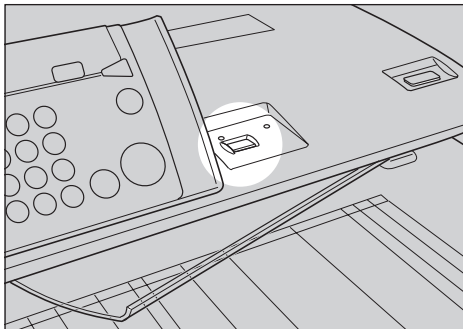

ZEDH110E

Turning Off the Main Power

- 1 Turn the main power switch to the Off position.

The main power indicator goes out.

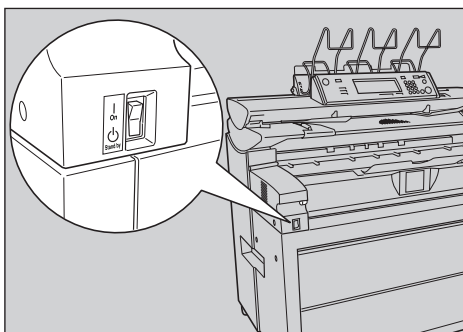

ZEDH381E

Anti-humidity Heater Switch

During the winter when there can be sudden changes in temperature, or during humid seasons, the paper in the paper roll tray can absorb moisture. This can cause the quality of the copies to deteriorate.

To prevent this, the machine has a built-in anti-humidity heater.

There is a switch for the anti-humidity heater in the upper tray and the optional lower tray. Turn this switch on if the humidity level become high and the quality of the copies are effected. Turn the switch off when it is not needed. See P.19 "Handling paper"

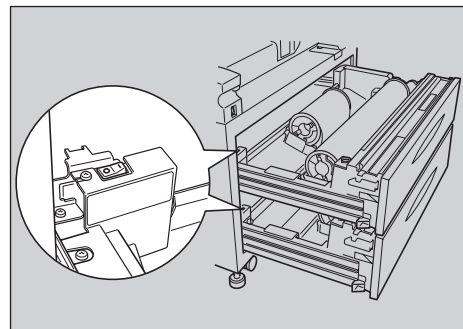











ZEDH120E

Originals











1

Sizes and Weights

❖ Metric version

Where original is placed	Original Size	Original Weight
Original table	Standard sizes; A0  , A1  , A2  , A3  , A4  , B1  , B2  , B3  , B4  , B5 	20.9 – 157g/m ² (18 – 135kg) and 0.03 – 1mm thick originals
	Custom sizes; Original length 182 – 6000mm Original width 210 – 914mm (Maximum width 950mm)	

❖ Inch version

Where original is placed	Original type	Original size	Original weight
Original table	Standard size	<ul style="list-style-type: none"> Engineering E(34"×44") , D(22"×34") , C(17"×22")  B(11"×17") , A(8½"×11")  Architecture E(36"×48") , 30"×42" , D(24"×36")  C(18"×24")  B(12"×18") , A(9"×12")  	20.9 - 157g/m ² (5.6 - 41.8 lb) and 1.1 Mil - 40 Mil thick originals
	Custom size	Length: 7.2" - 236" Width: 8.3" - 36" (Maximum width : 37.5")	

Originals that should be scanned using the carrier sheet

The following type of originals should be mounted on the carrier sheet. You should also use the carrier sheet for important originals and for originals you will copy repeatedly.

- Cut and pasted originals
- Originals with fold lines
- Wrinkled or torn originals
- Waved originals
- Punched originals
- Originals with sticky tape or starch

- Pasted originals
- Originals with a damaged leading edge
- Photos or other originals that easily attracted to glass
- Originals drawn with a pencil

 **Reference**

⇒ P.32 "*Setting Carrier Sheet*"

Non-recommended original

The following original types can cause jams, or the original itself might be damaged.

- Originals other than those specified in P.13 "*Sizes and Weights*"
- Stapled or clipped originals
- Perforated or torn originals
- Bent, folded, or creased originals
- Pasted originals
- Originals with any kind of coating, such as thermal fax paper, art paper, aluminum foil, carbon paper, or conductive paper
- Originals with indexed, tags, or other projecting parts
- Sticky originals such as translucent paper (vellum)
- Bound originals such as books
- Damp originals
- Badly curled originals
- Originals that vary in thickness
- Originals with stick tape or adhesive
- Originals with thick leading edges
- Originals with ink or correction fluid that has not dried
- Carbon backed originals
- Originals not made of paper (such as glass, metal)
- The roll diameter smaller than $\phi 35\text{mm}$ ($\phi 1.4''$).
- The roll diameter larger than $\phi 110\text{mm}$ ($\phi 4.3''$).

Originals that use more than 20% of image area, may the image to cause be faint. Adjust curled originals so that they fit within the range shown below.

- Front and back curl; R 60mm, 2.4" or more, Height 10mm, 0.4" or less

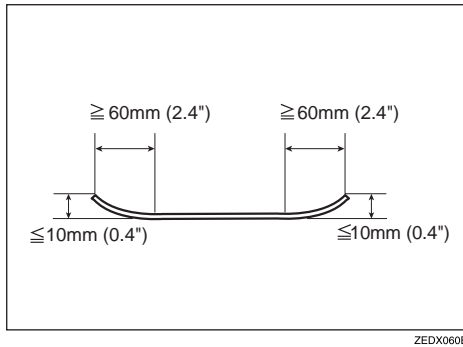

1

Missing Image Area

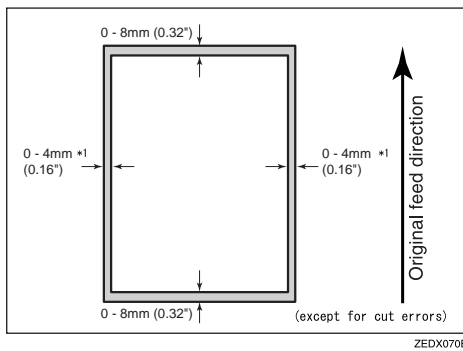

As shown above, part of the original may not be copied (using full-size copying).

*1: On left and right, less than 5mm, 0.2"

Copy Paper

1

Recommended Size and Type

The following limitations apply to each paper roll tray and bypass tray.

❖ Metric version

Where paper is placed	Paper type	Paper size	Number of sheets that can be placed
Paper roll tray	Plain paper 52.3 – 110g/m ² (13.9 – 29.3 lb)	Roll Paper Diameter: less than 170mm Core: 75.7mm – 77mm	–
	Translucent paper	Width: 210, 257, 297, 364, 420, 515, 594, 660, 728, 800, 841, 880, 914mm	
	Film	Roll length: less than 150mm	
Bypass Tray	Plain paper 52.3 – 110g/m ² (13.9 – 29.3 lb)	A0 ☐ A1 ☐ A2 ☐ A3 ☐ A4 ☐ B1 ☐ B2 ☐ B3 ☐ B4 ☐	1 sheet
	Translucent paper	Paper width: 182 – 914mm	
	Film	Paper length: 182 – 2000mm	

❖ Inch version

Where paper is placed	Paper type	Paper size	Number of sheets that can be placed
Paper roll tray	Plain paper 52.3 – 110g/m ² (13.9 – 29.3 lb)	Roll Paper Diameter :6.7" or less Internal diameter: 2.98" - 3.03"	–
	Translucent paper (vellum)	Width: 8½", 9", 11", 12", 17", 18", 22", 24", 34", 36"	
	Film	Roll length: 5.9" or less	
Bypass tray	Plain paper 52.3 – 110g/m ² (13.9 – 29.3 lb)	<ul style="list-style-type: none"> • Engineering E(34"×44") ☐, D(22"×34") ☐ C(17"×22") ☐ B(11"×17") ☐, A(8½" × 11") ☐ • Architecture E(36"×48") ☐, D(24"×36") ☐ C(18"×24") ☐ B(12"×18") ☐, A(9"×12") ☐ 	1 sheet
	Translucent paper (vellum)		
	Film		

Note

- ❑ Please use recommended paper. Although you can use other copier paper, if it matches the paper specifications.

Reference

⇒ P.12 “*Anti-humidity Heater Switch*”

1

Roll paper

- If the humidity level is high, and the roll paper has expanded due to the moisture, cut off approximately 1000mm, 40" immediately before making copies.
- Use roll paper that has a black core.

Notes on using translucent paper (vellum)

Smooth out any curl in the paper before using it.

When loading translucent paper (vellum), load it lengthways, whenever possible.

Hemmed paper

When using hemmed paper, wrinkles and other problems may occur in your copies. Use the following procedure when copying onto hemmed paper.

- Make the copy using the bypass tray.
- Make sure that the paper is straight, and align the paper guides of the bypass tray with the paper size.
- Load only one sheet at a time.
- Remove each copy from the output tray and place it on a flat surface.
- Store opened paper in a plastic bag so that it will not become damp.

Note

- ❑ Due to the thickness of hemmed paper, the copies may be faint, blurred, paper may wrinkle, or paper jams may occur. You may be able to prevent this by copying on the rear surface of the paper or feeding the bottom of the paper in first.

Non-recommended paper

⚠ CAUTION:

- *Do not use aluminum foil, carbon paper, or similar conductive paper to avoid a fire or equipment failure.*

1

Do not use the following types of paper. They may cause paper misfeeds.

- Bent, folded or creased paper
- Torn paper
- Punched paper
- Sticky paper (paper that sticks together)
- Slippery paper
- Thin paper that has low stiffness
- Adhesive labels
- OHP transparencies

If you make a copy on rough grain paper, the copy image might be blurred.

If the paper is curled, you may not be able to make clear copies.

When using paper other than recommended paper (such as especially with chemically treated paper, hemmed paper, film), paper jams may occur, the paper may wrinkle, or copy image may deteriorate.

Do not use paper with any kind of coating, such as thermal fax paper, art paper, aluminum foil, carbon paper, or conductive paper. These can damage the machine.

Do not use paper which has been copied or printed on.

Do not copy on both sides of the paper.

If you use roll paper that is not marked with a black core, paper jams can occur when the paper is ended.

Paper storage



When storing paper, you should always observe the following precautions.

- Do not store paper where it will be exposed to direct sunlight.
- Storing paper in dry areas (humidity: 70% or less).
- Store on a flat surface.
- Keep open reams of papers in the package, and store as you would unopened paper. Under high temperature and high humidity, or low temperature and low humidity conditions, store papers in a plastic bag.

Handling paper

Depending on the humidity of the storage conditions, handle the paper as follows:

1

%	State of copies	Try this...
High humidity 	Part of the copy image is lost or a multi-sheet feed, or wrinkling occurs both on translucent paper (vellum) and normal paper.	<ul style="list-style-type: none"> • Improve the environment where the copier is placed (e.g., install an air conditioner or dehumidifier). • Remove paper from the copier immediately after copying, and store it in a plastic bag.
70 (Normal conditions)	Part of the copy image is lost both on translucent paper (vellum) and normal paper.	<ul style="list-style-type: none"> • When you do not use the copier for a long time, remove paper from the copier and store it in a plastic bag.
40 	Part of the copy image is lost on translucent paper (vellum).	<ul style="list-style-type: none"> • Store paper in a plastic bag when you have finished copying each day.
Low humidity	Part of the copy image is lost or a multi-sheet feed, or wrinkling occurs both on translucent paper (vellum) and normal paper.	<ul style="list-style-type: none"> • When you do not use the copier for a long time, remove translucent paper (vellum) from the copier and store it in a plastic bag. • Improve the environment where the copier is placed (e.g., install an air conditioner or humidifier). • Remove paper from the copier immediately after copying, and store it in a plastic bag.

Note

- If the humidity level is above 70%, turn on the anti-humidity heater.

Reference

⇒ P.12 "Anti-humidity Heater Switch"

Toner

1

Handling

⚠ WARNING:

- *Do not incinerate used toner or toner containers. Toner dust might ignite when exposed to an open flame. Dispose of used toner containers in accordance with local regulations for plastics.*

⚠ CAUTION:

- *Keep toner (used or unused) and toner containers out of reach of children.*

⚠ CAUTION:

- *Our products are engineered to meet high standards of quality and functionality, and we recommend that you only use the expendable supplies available at an authorized dealer.*

⚠ Important

- If you use toner other than recommended, a problem might occur.

Storage

When storing toner, always follow these precautions.

- Store toner containers in a cool, dry place away from direct sunlight.
- Store on a flat surface.

Usage

Used toner cannot be re-used.



2. Copying

Before Copying

Before you start copying, specify the original and copy paper locations.

❖ Paper Capacities For Each Original/Paper Output

Original output	Original Output (Upper)	A1 (D)☐ 50 sheets (Plain paper) or smaller: 20 sheets (Translucent paper (vellum))
		<ul style="list-style-type: none"> • Use originals that are the same size, and of medium or high quality paper. • Do not use paper that is long length paper, thick, curled, film, folded, or translucent paper (vellum) that is less than 80g/m² (21.3 lb) in weight. • Do not load more than 10 sheets during very hot or humid conditions. • Output thick paper (104.7g/m² (27.9lb) or more) to Rear (Straight). • Translucent paper (vellum): 80g/m² (21.3 lb) or less, plain paper: 52.3g/m² (13.9 lb) or less, and originals that are not stiff should be output to Rear (Straight).
	Original Output (Rear (Straight))	A0 (E) or less: 1 sheet (plain paper) 1 sheet (translucent paper (vellum)) 1 sheet (film)
		<ul style="list-style-type: none"> • A1 (E)☐ When using these types of original, the ejected originals may interfere with the copy paper and impede its progress. If this happens, use the copy output (rear) auxiliary guide. • When using A0 (E) size originals, remove the originals one at a time.
	Document Roller	A1 (D)☐ or above: 1 sheet (Up to 6m (236")) (plain paper) 1 sheet (Up to 3.6m (141")) (Translucent paper (vellum)) 1 sheet (Up to 3.6m (141")) (film)
		<ul style="list-style-type: none"> • Use face-curl originals. • For roll originals, use originals with a diameter of roll Φ40mm – Φ110mm (Φ1.6" – Φ4.3").

Copy out-put	Copy Out-put (Front)	A1 (D)  or less: 99 sheets (plain paper) 10 sheets (translucent paper (vellum)) 1 sheet (film)
		<ul style="list-style-type: none"> • Same size copy paper
	Copy Out-put (Rear)	A1 (D)  , A0 (E): 10 sheets (Plain paper) 1 sheet (Translucent paper (vellum)) 1 sheet (film)
		<ul style="list-style-type: none"> • Same size copy paper • When using A0 size copy paper, attach the copy output (rear) auxiliary guide. See P.26 "Using rear output for A0 (E) Paper"

Important

- ☐ The paper capacity indicated assumes the use of standard copier paper, and should only be used as a guide. If the paper exceeds the upper limit, the copies may become folded or cause paper jams.

Switching the Original Exit

Select the appropriate output from **[Upper]**, **[Rear (Straight)]**, or **[Rear (Document Roller)]**, for the type of original you are using.

❖ **Upper** 

This is the basic output exit for originals. The originals are ejected to **[Original Output (Upper)]**.

❖ **Rear (Straight)** 

When copying thick, or hard, originals, select **[Original Output (Rear (Straight))]**. The originals are ejected to **[Original Output (Rear (Straight))]**.

❖ **Rear (Document Roller)** 

If you select **[Rear (Document Roller)]** when copying long length originals, the original is ejected to document roller. See P.24 "Original output (Rear (Document Roller))".

Important

- ☐ Use the carrier sheet with **[Original Output (Rear (Straight))]**. If you use **[Original Output Rear (Upper)]**, your originals may be damaged.

Original output (Upper)

- 1 Press the [Upper] key.

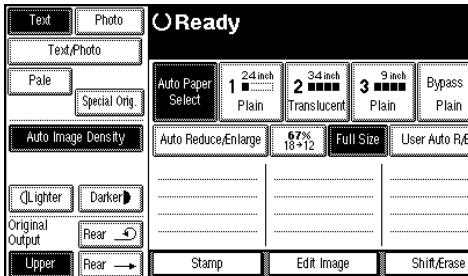

2

Original output (Rear (Straight))

- 1 Check that the document roller is raised.
- 2 Press the [Rear (Straight)] key.

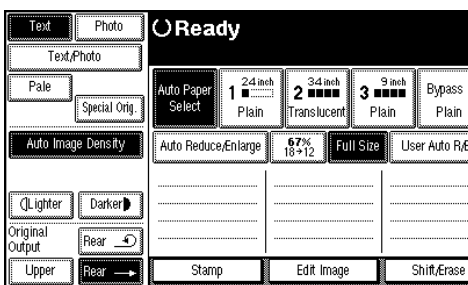

 **Note**

- After originals have been ejected, they are held at the original output exit. This is due to the paper edge hold function, which helps protect your originals. To cancel this function, press the **[Scanner Stop]** key. When you press the **[Rear (Document Roller)]** key, the originals will not be gathered together.

Original output (Rear (Document Roller))

1 Lower the document roller.

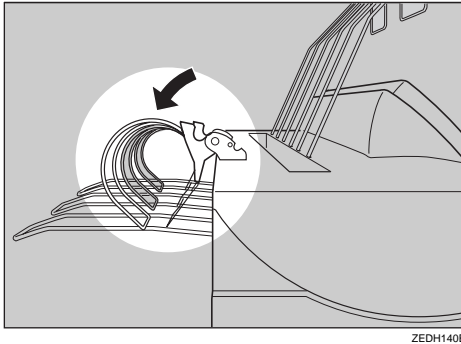

2

Note

- When using the document roller, use paper with the following range;
52.3g/m² – 104.7g/m² (13.9 lb – 27.9 lb)

2 Press the [Rear (Document Roller)] key.

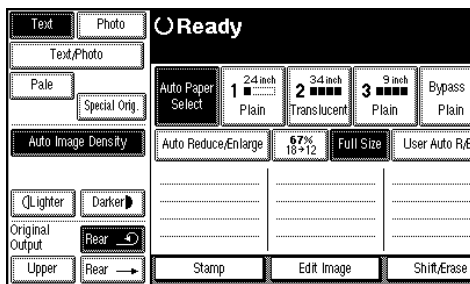

3 After the original has been ejected, pull the document roller forward and remove the original.

Adjusting The Original Tray (Option)

When using the optional original tray, adjust the hook position to the size of the original.

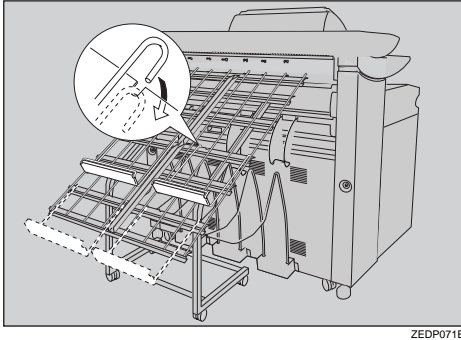

2

Switching the Copy Exit

Select **[Front]** or **[Rear]** for the copy output exit.

❖ Front Output

When **[Front]** is selected, the copies are sent to the copy output (front) tray at the front of the machine.

When copying A1 (D) or less, select front output.

❖ Rear Output

When **[Rear]** is selected, the copies are sent to the copy output (rear) tray at the back of the machine.

When copying A1 (D) or A0 (E) , select rear output.

Front output

1 Press the **[Front]** key.

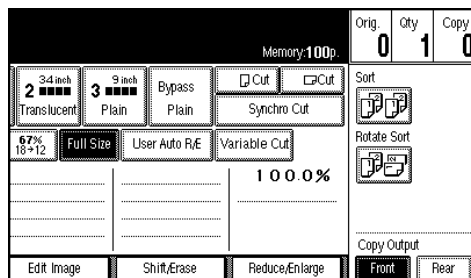

Important

- ❑ If you copy roll originals to the copy output (front) auxiliary tray and Front is selected for the copy output location, the original in the auxiliary tray may interfere with the copy output. This may cause damage to the originals or paper jams. If you use the scan first function, copying does not start until you press the **[Start]** key, you can prevent this. If you frequently copy long originals like those above, you should set the scan first function using Print Start Trigger. See P.128 "Print Start Trigger"

Rear output

- 1 Press the **[Rear]** key.

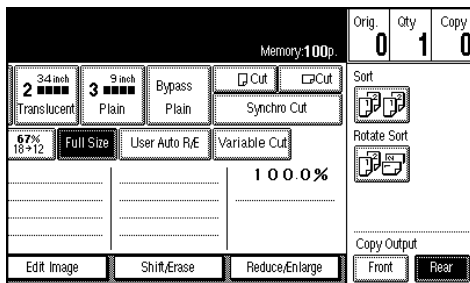

Note

- ❑ When using thick paper, the last sheet to be ejected can remain in the exit area. If at sheet remains in the exit area, remove it.

Using rear output for A0 (E) Paper

When using rear output for A0 (E) size paper, the leading edge of the paper can become caught in the back of the copy output (rear) tray. If you attach the copy output auxiliary guide you can prevent this.

- 1 Lower the copy output auxiliary guide and adjust the position.

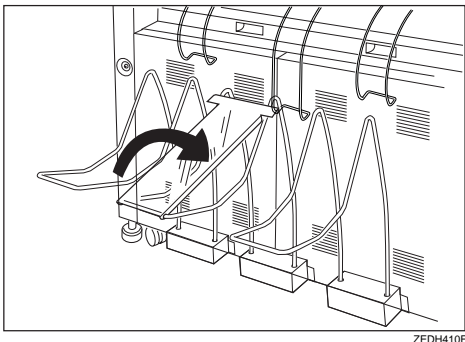

 **Note**

- You do not need to use the copy output auxiliary guide when copying on to A1 (D), or shorter paper.

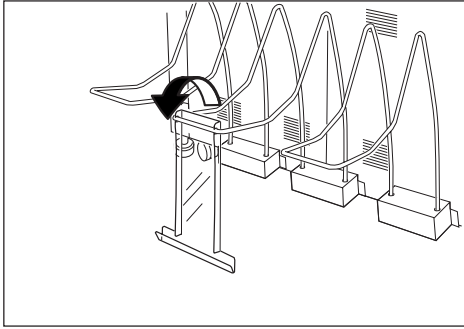

ZEDH420E

2

Basic Procedure

2

Preparation

You can specify whether the machine automatically starts to make copies or if you need to press the **[Start]** key before it starts copying. See P.128 "Print Start Trigger"

The default setting is to start automatically.

- 1 When the machine is set for a user code, enter the user code with the number keys, and then press the **[#]** key.

The machine is ready to make copies.

- 2 Make sure the message "Ready" is displayed on the screen.

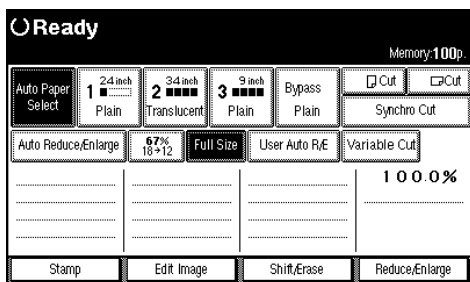

- 3 Make sure that there are no previous settings remaining.

Note

- To clear settings, press the **[Clear Modes/Energy Saver]** key.

Reference

For details about the settings for the Initial Screen that appears when you press the **[Clear Modes/Energy Saver]** key, see P.126 "General Features 1/2".

When the message "To make an additional copy, press Start Key." appears, the previous settings and image of the scanned original are saved in machine memory. Press the **[Clear Modes/Energy Saver]** key to clear the settings. See P.36 "Additional Copy"

- 4 Set your desired settings.

Note

- The settings are displayed on the screen.

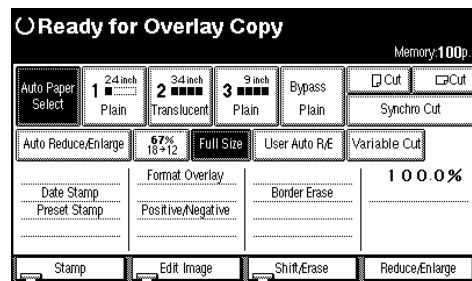

Reference

For details, see explanations of each function.

If you use the **[Program]** key to access the program function, you can store and easily call up the settings. See P.53 "Program"

- 5 Select the paper.

Reference

P.42 "Selecting Copy Paper"

6 Place your originals.

The originals are fed into the machine.

Important

- ❑ Once the originals start to feed into the machine, do not push or pull them. This may damage your originals.

Note

- ❑ Insert the originals so that the right edge is aligned with the original guide.
- ❑ Release the original when it is pulled slightly into the machine.
- ❑ Immediately after the machine is turned on, or if the temperature is low, or if making a lot of continuous copies (more than 30 sheets/A0, (more than 30 sheets/E size)), the continuous copy speed may be down to ensure the toner fuses to the paper. This is called CPM down.
- ❑ To stop originals being fed into the machine, press the **[Scanner Stop]** key.

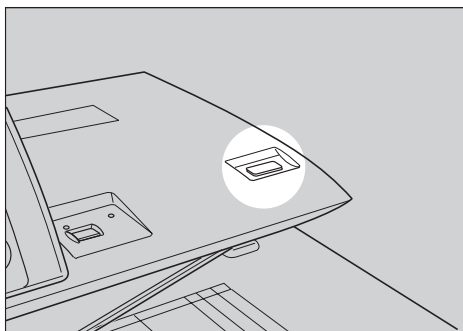

ZEDH150E

- ❑ When you press the **[Scanner Stop]** key, the original stops immediately, which can cause the original to jam. If this happens, see P.117 “**Clearing Misfeeds**”

- ❑ To pause or cancel a copy job, press the **[Clear/Stop]** key. When you press the **[Clear/Stop]** key, the machine stops after the current copy (one sheet) has finished.

Reference

- ⇒ P.31 “*Setting Originals*”
- ⇒ P.21 “*Paper Capacities For Each Original/Paper Output*”

7 The machine starts copying.**Note**

- ❑ When Scanner Stop Trigger setting is set to on, copying starts when you press the **[Start]** key. See P.128 “*Print Start Trigger*”

Original Counter/Reset

After the originals have been scanned, the number of originals is displayed in the right corner of the screen. This allows you to check the number of originals in a job, or to check if any sheets have been fed together, and can also be used as a guide for the number of copies that will be stored in the copy output tray.

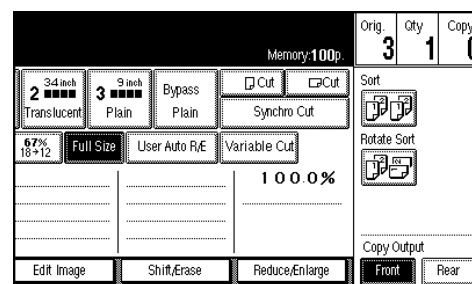
**Resetting the original counter**

- 1** Press the **[Orig.]** key and the count number in the top right corner of the screen.

The number is reset to 0.

Auto Reset

The machine returns to its initial condition automatically after your job is finished, after a certain period of time. This function is called "Auto Reset".

Note

- The default settings that after Auto Reset, or after the **[Clear Modes/Energy Saver]** key has been pressed, is as follows.

Auto Image Density	On
Combined Auto and Manual Density	On * ¹
Default image density	Centre
Synchro Cut	On
Selected paper roll	Paper Roll 1 * ²
Full size	On

*¹ : Density Priority setting can be changed

*² : Paper Roll Priority setting can be changed

- You can store the settings you want to use as the default settings for the Initial Screen in Program No. 20. See P.126 "Initial Mode Set", P.53 "Program"
- You can change the Auto Reset time. See P.126 "Copier Reset Timer"
- In some cases Auto Reset will not reset the settings.
 - If a paper roll tray is open
 - If there is an original or paper jam
 - If a cover is open
 - If copying has been interrupted
 - During copying (if only one original has been inserted when using Image Overlay)

- During copying (if there is no paper in the bypass tray after a manual copy original has been scanned)
- When the "PLEASE WAIT" is displayed (such as while the machine is warming up)

Auto Off

The machine turns itself off automatically after your job is finished, after a certain period of time. This function is called "Auto Off".

Note

- You can change the Auto Off time. For Auto Off time setting, see "Auto Off Timer" of the "System Settings" manual.
- In some cases the machine will not automatically turn itself off.
 - If there is an original or paper jam
 - If a cover is open
 - If copying has been interrupted
 - During copying (if only one original has been inserted when using Image Overlay)
 - During copying (if there is no paper in the bypass tray after a manual copy original has been scanned)
 - When the "PLEASE WAIT" is displayed (such as while the machine is warming up)

Setting Originals

Note

- ❑ Place the original after correction fluid and ink has completely dried. Not taking this precaution could mark the exposure glass and cause marks to be copied.
- ❑ Dust and residue from originals drawn with a pencil can mark the exposure glass and cause marks to be copied. We recommend using the carrier sheet for this type of original.
- ❑ If the rear edge of the original is badly curled, smooth out the curl with both hands before scanning the original. If the original is inserted as it is, it may be damaged.
- ❑ When copying curled originals, use the copy output (front) auxiliary tray.
- ❑ Do not use force to push the side fence of the original guides.

Reference

For details about precautions with originals, see P.13 "Originals"

- 1** Adjust the original guides to the size of the paper width.

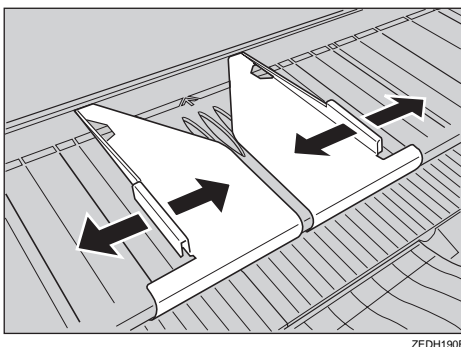

Note

- ❑ Make sure that the original guides are not too tight.

- 2** Carefully place the original between the original guides, using both hands, with the side to copied face up.

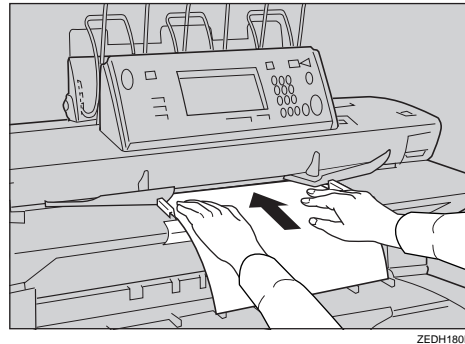

2

Important

- ❑ Do not release your hands until that the original is pulled into the machine.
- ❑ Once the originals start to feed into the machine, do not push or pull them. This may damage your originals,
- ❑ If the originals are fed at a slant or become jammed, press the **[Scanner Stop]** key.

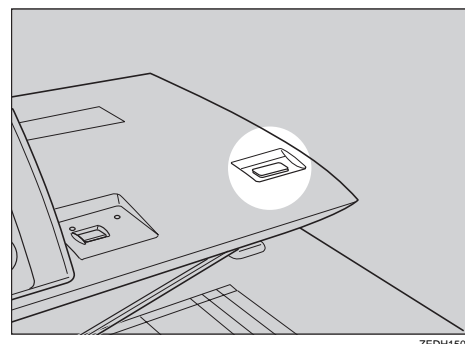

- ❑ Do not operate the document roller while originals are being fed through the machine. This may damage your originals,

Note

- ❑ Release the original when it is pulled slightly into the machine.
- ❑ To stop originals being fed into the machine, press the **[Scanner Stop]** key.
- ❑ When you press the **[Scanner Stop]** key, the original stops immediately, which can cause the original to jam. If this happens, see P.117 "*Clearing Misfeeds*".
- ❑ When you have used the **[Rear (Straight)]** key to specify the original output location, the rear edge of the originals are held at the output exit. You can cancel this by pressing the **[Scanner Stop]** key. See P.22 "*Switching the Original Exit*".
- ❑ You can change the original feed delay setting if originals are repeatedly fed at a slant or if you need to adjust the delay for the type of originals you are using. See "Original Feed Delay 1" in the System Settings manual.
- ❑ If the leading edge of the original is badly curled, smooth out the curl and place the original in the insertion area.
- ❑ When inserting long length originals, there may be some movement to either side. If this occurs, correct the movement manually while feeding the original into the machine.

Setting Carrier Sheet**Important**

- ❑ When using the carrier sheet, set the original output location to original output (rear (straight)). If the original output location is set to **[Upper]** or **[Document Roller]**, the original may be damaged.

Note

- ❑ When using the carrier sheet and Synchro Cut is selected, the paper is cut to the size of the carrier sheet.

Reference

For details about using the carrier sheet to make copies see P.13 "*Originals that should be scanned using the carrier sheet*".

- 1** Open the carrier sheet with the transparent sheet face up and then insert the original also face up.

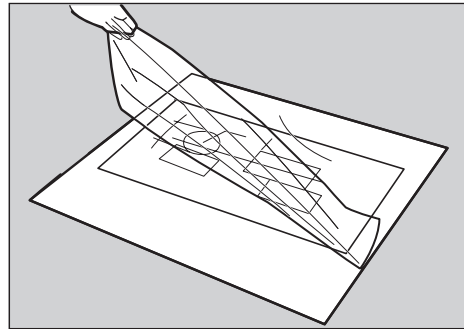

ZEDP020E

Note

- ❑ Align the original with the fold of the carrier sheet.

- 2** Hold the original with both hands with the side to be copied face up, and gently feed the folded edge of the carrier sheet into the insertion area.

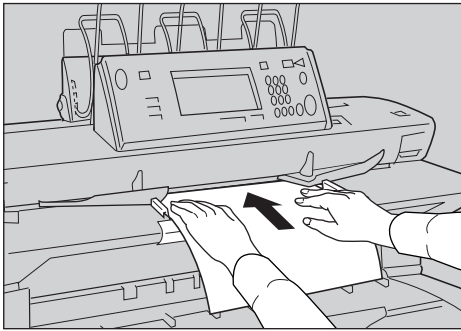

ZEDH180E

2

Important

- Once the originals start to feed into the machine, do not push or pull them. This may damage your originals.
- If the originals are fed at a slant or become jammed, press the **[Scanner Stop]** key.

Note

- Place the original with the side to be copied face up.

Repeat Copy

Making several copies of a single original is called "Repeat Copy".

- 1 Enter the number of copies required with the number keys.

2

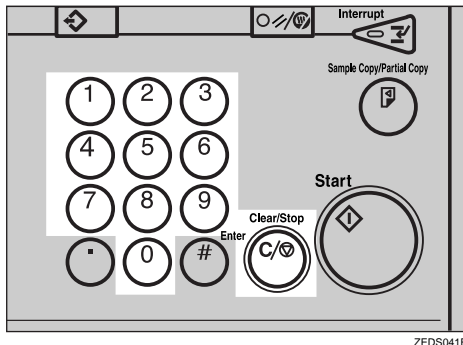

ZEDS041E

Note

- ❑ The maximum copy quantity can be set from 1 to 99.
- ❑ To change the value entered, press the **[Clear/Stop]** key, and then enter the new value.
- ❑ You can change the upper limit for the number of copies. See P.128 "Maximum Copy Quantity"

- 2 Place your originals.

Reference

⇒ P.31 "Setting Originals"

Interrupting a Repeat Copy job

You can interrupt a Repeat Copy job and change the settings.

- 1 Press the **[Clear/Stop]** key.

The machine stops after the sheet that is being copied is finished.

- 2 To cancel the job, press the **[Stop]** key. To continue copying, press the **[Continue]** or the **[Start]** key.

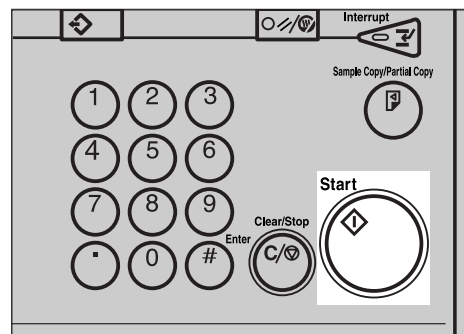

ZEDS051E

Reference

⇒ P.35 "Restart Copy", P.36 "Additional Copy"

Restart Copy

You can resume copying with the same settings after replacing paper, replacing toner, cleaning paper jams or after a copying pause by pressing the **[Clear/Stop]** key.

2

Note

- You can change the number of copies from the previous setting when using Restart Copy.

- 1** To change the number of copies, enter the new number of copies with the number keys.

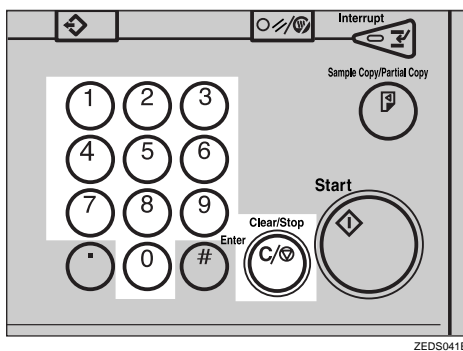

ZEDS041E

Note

- To change the value, press the **[Clear/Stop]** key and enter the new value.

- 2** Press the **[Start]** key.

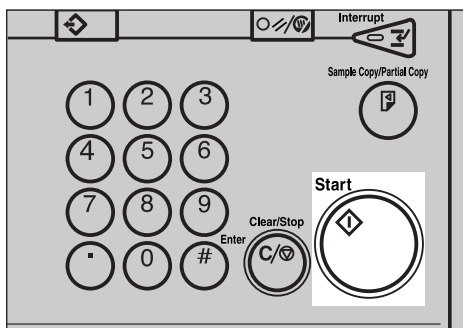

ZEDS051E

Additional Copy

You can change the copy function settings and make additional copies after you have finished copying, or after a copying pause by pressing the **[Clear/Stop]** key. When you make additional copies, the message "To make an additional copy, press Start Key." appears on the screen.

2

Limitation

- You can change the following functions when using Additional Copy.
 - Number of copies
 - Paper roll selection
 - Fine Magnification
 - Shift
 - Margin
 - Border Erase
 - Double Copies
 - Front output/Rear output
- If paper roll was selected as the paper source in the original settings, you cannot select the bypass tray.
- If a function from the optional Print function was selected in the original settings, you can change Print type, if you did not select a Print function in the original settings, you cannot select them for Additional Copy.
- If Image Repeat was selected in the original settings, you can change or delete the setting. If you did not select the Image Repeat function in the original settings, you cannot select it for Additional Copy.

- 1** Check that the message "To make an additional copy, press Start Key." is displayed on the screen.

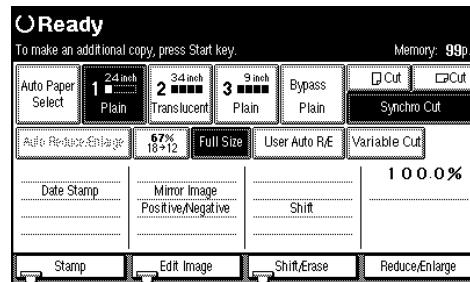

- 2** Add or change function settings.

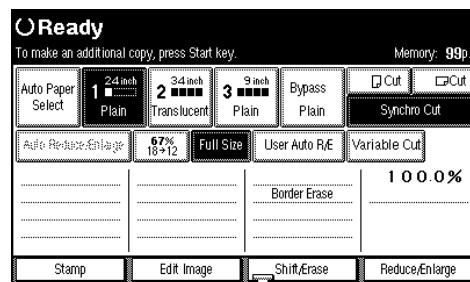

Important

- If you make a mistake entering the settings, press the function key again to cancel the settings or press the **[Clear/Stop]** key to cancel the settings. If you press the **[Clear Modes/Energy Saver]** key, you can delete the scanned image of the original from memory.

- 3** Press the **[Start]** key

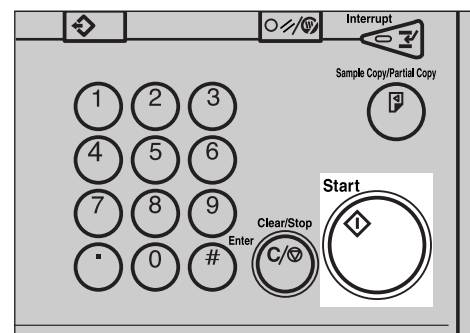

ZEDS051E

Job Preset

If a long copy job is in progress and you do not wish to wait for it to finish, you can use this function to set up the next copy job in advance. When the current copy job is finished, your copy job will be started automatically.

Limitation

- Job preset is one job for one original.
- The number of jobs that can be preset for Job Preset and each paper size is as follows:

	Standard	Optional HDD installed
A0(E)	—	49 jobs *1
A1(D)	1 job	99 jobs
A2(C)	3 jobs	99 jobs
A3(B)	7 jobs	99 jobs
A4(A)	15 jobs	99 jobs

*1 Depending on the function settings, you may be able to store more originals.

- You cannot use the following functions with Job Preset. Make the settings when the current copy job has finished.
 - Recalling a Program
 - Interrupt Copy
 - Copying From The Bypass Tray
 - Sort
 - Image Overlay
 - Double Erase
 - Image Repeat
 - Preset Stamp
 - User Stamp
 - User Stamp Repeat
 - Sample Copy
 - Partial Copy

- You cannot preset a job while a job is being sorted.
- The maximum number of jobs that can be preset is 99.
- Depending on the size of original, you may not be able to preset more jobs even if have not reached the maximum.
- You can select the paper for Job Preset, but if the paper for the previous job was set to Plain, Film, or the Fusing mode setting for Translucent paper (vellum) was set to 1 or 2, the fusing mode setting will not be used. In these cases, make the copies after Job Preset has finished. See "Fusing Adjustment: Paper Tray" in the System Settings manuals.

- 1** Press the [Job] key while the message "Copying..." is displayed.

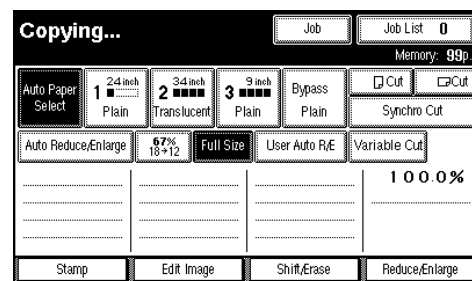

Note

- You can specify the number of originals or jobs that can be scanned for Job Preset.
- If the number of jobs is full, you cannot preset any more jobs even if memory is still available. For details about the memory display, see P.128 "Memory Status Display".

2

2 Make the settings for the copy job you want to preset.

Note

- To cancel a setting while making the preset settings, press the **[Clear Modes/Energy Saver]** or **[Delete]** key.

3 Place the originals. The machine scans the originals.

When copying has finished, the preset job start automatically.

Note

- If you press the **[Job list]** key, you can check the settings and preset conditions. The **[Exit]** key the current copy job is displayed on the screen.

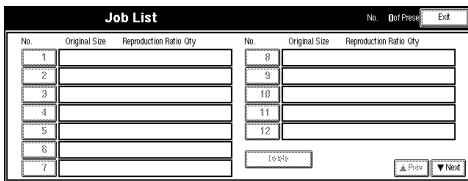

3 Press the **[Delete]** key.

4 Press the **[OK]** key.

Note

- To cancel the deletion, press the **[No]** key.

Deleting a Job Preset

Limitation

- You cannot the Job Preset settings while it is being copied.

1 Press the **[Job list]** key.

The Job list is displayed on the screen.

2 Select the number for the job you want to delete.

Note

- If the number of the Job Preset you want to delete is not displayed, press the **[▲Prev.]** **[▼Next]** keys to display it.

Interrupt Copy

Use this function if you wish to interrupt a long copy job to make urgently need copies.

⚠ Limitation

- ❑ You cannot use Interrupt Copy while the following types of copies are being made.
 - Copying From The Bypass Tray
 - Sort
 - Image Overlay

1 Press the **[Interrupt]** key.

The key indicator lights up.

The Interrupt key lights up and copying stop.

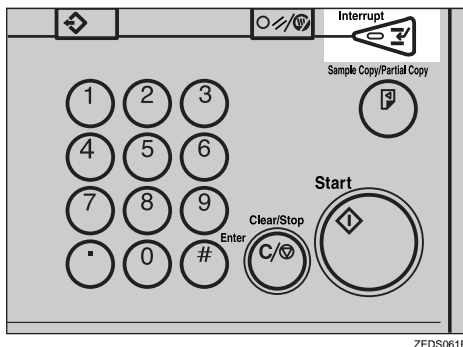

2 Make the settings for the Interrupt Copy job.

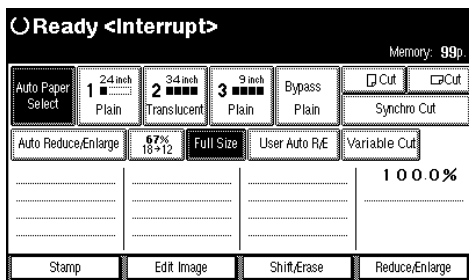

⚠ Limitation

- ❑ You cannot use the settings for Sort, Edit Image, Stamp, Erase, or Job Preset.

3 Place your originals.

4 When copying has finished, remove the copy output for the Interrupt Copy job.

5 Press the **[Interrupt]** key again.

The Interrupt key indicator goes out.

2

Resuming the previous copy job

1 Place your originals, and then press the **[Start]** key.

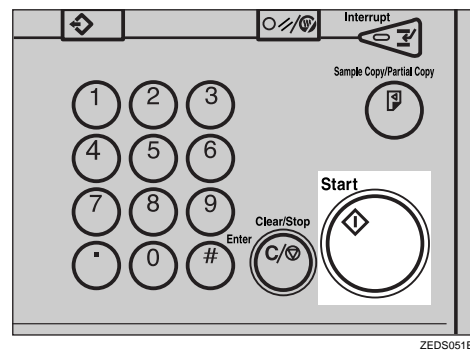

Exiting

1 Press the **[Clear Modes/Energy Saver]** key.

Basic Functions

2

Selecting Original Type Setting

Select one of the following original types to match your originals.

The following image quality modes are available.

- ❖ **Text**
Use this mode to scan originals that contain mainly text, or printed characters.
- ❖ **Text/Photo**
Use this mode to scan originals that contain a mixture of text and photographs or pictures.
- ❖ **Photo**
Use this mode to scan photographs or pictures.
- ❖ **Pale**
Use this mode to scan originals that have faint lines drawn with a pencil, or faintly copied receipts or slips. The faint lines will be copied clearly.
- ❖ **Special Orig. – Blue Line**
Use this mode to copy images drawn on section paper (blue or green sectioned graph paper) without copying the lines of the paper.
The original waited sepia line can not use.
- ❖ **Special Orig. – Patched Org**
Use this mode to copy originals with different background densities without the darker background being too prominent.

- ❖ **Special Orig. – Photo (Hard Tone)**

Use this mode to scan posters that contain photos with text overlays, which require a strong contrast setting. Use Photo mode to copy glossy photographs and other simple pictures.

- ❖ **Special Orig. – Generation**

Use this mode to scan originals that are already copies. This will copy the image while suppressing the width of the characters. It also eliminates any specks on the image.

- 📌 **Limitation**

- Use this mode to scan originals that contain fine lines (width of 1mm, 0.04" or less). This mode will regard thick lines, text or solid blocks as textures, which may result in parts of the image not being copied.

- 📌 **Note**

- You can select a Noise Reduction level of **[Low]**, **[Medium]** or **[High]**, for each of the original types. The default setting is **[Off]**. See P.129 "Noise Reduction"
 - You can also select a Copy Image Density level of Lighter, Normal or Darker, for each of the original types. See P.129 "Manual Image Density Level"

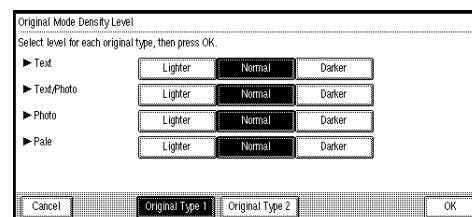

- You can also adjust the image quality for each of the original types. See P.129 “Original Mode Quality Level”

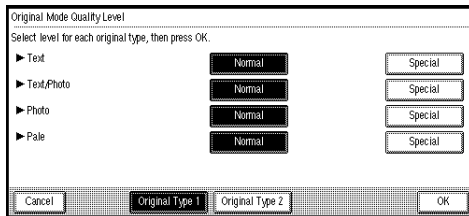

1 Select the original type.

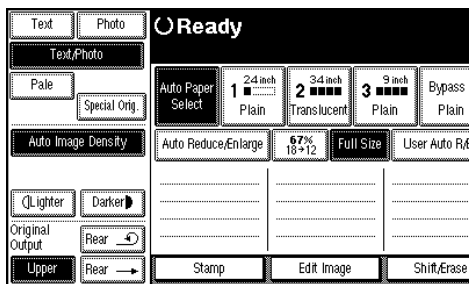

Note

- If you select **[Photo]**, the Auto Image Density function is cancelled.
- If you press the **[Special Orig.]** key, you can select **[Generation]** or one of the other special original types.

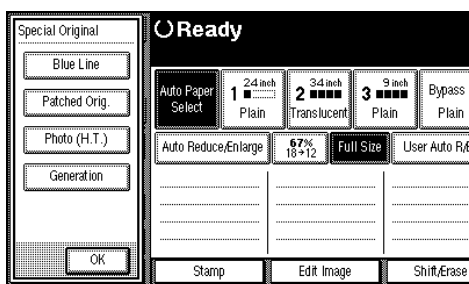

Adjusting Copy Image Density

Preparation

You can adjust the copy density to match your originals. There are three types in this function.

❖ Auto Image Density

The machine automatically adjusts the image density.

❖ Manual Image Density

If you require darker or lighter copies, adjust the image density yourself.

❖ Combined Auto and Manual Density

Use when copying originals with a dirty background (such as newspapers). You can adjust the foreground density while leaving the background unchanged.

Note

- You can specify whether or not to use Auto Image Density by selecting on or off.
- You can specify the default density setting for each of the original types. See P.127 “Density Priority”

1 Select the method for adjusting the image density.

2

2

Auto image density

- 1 Make sure that the **[Auto Image Density]** key is selected.

If it is selected, the Auto Image Density section will be inverted.

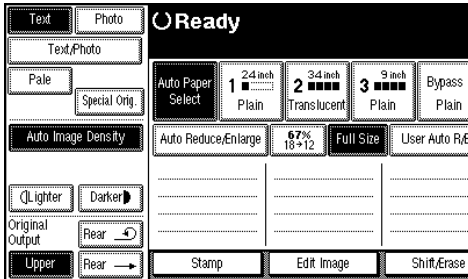

Note

- If Auto Image Density function is not selected, press the **[Auto Image Density]** key.

Manual image density

- 1 If Auto Image Density is selected, press the **[Auto Image Density]** key to cancel.
- 2 Press the **[Lighter]** or **[Darker]** keys to adjust the image density.

The square icon in the image density display moves.

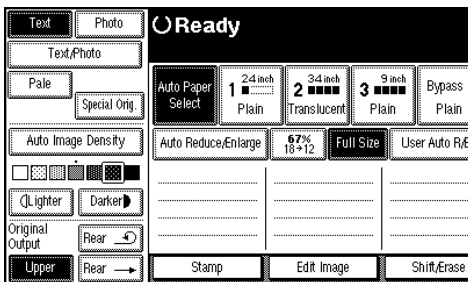

Combined auto and manual density

- 1 Make sure that the **[Auto Image Density]** key is selected.

Note

- If Auto Image Density is not selected, press the **[Auto Image Density]** key.

- 2 Press the **[Lighter]** or **[Darker]** keys to adjust the image density.

The square icon in the image density display moves.

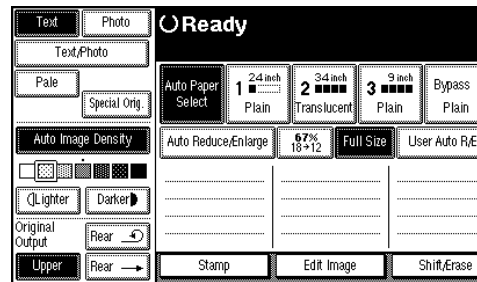

Selecting Copy Paper

Preparation

There are two ways to select copy paper.

❖ Auto Paper Select

The machine selects a suitable size of copy paper automatically based on the original size and the magnification.

❖ Manual Paper Select

Select the paper roll or bypass tray containing the paper you wish to copy onto: paper roll 1, paper roll 2, paper roll 3(option), and bypass tray.

Limitation

- ❑ If you select the tray paper type setting to **[Translucent]** or **[Film]** (except for **[Plain]** or **[Recycled paper]**), the auto paper select function will not be used. For tray paper type setting, see "Tray Paper Type" in the System Settings manual.
- ❑ If the type of paper changes when you select the paper source, it may take longer for copying to start.
- ❑ When using a 30" width original, set the original size auto detect setting to off. See P.128 "Original Size Auto Detect"

Note

- ❑ If you press the **[Clear Modes/Energy Saver]** key immediately after turning the power on, you can specify the paper roll to be used as the default setting for Auto Reset. The default setting is paper roll 1. See P.127 "Paper Roll Priority"

Reference

⇒ P.46 "Copying from the Bypass Tray"

Auto paper select

- 1 Make sure that the **[Auto Paper Select]** key is selected.

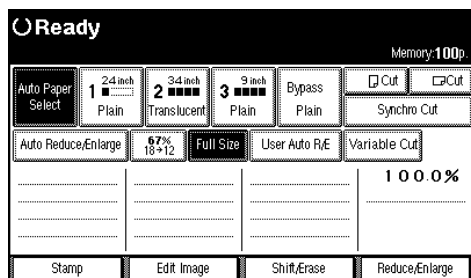

Note

- ❑ When Auto Paper Select is selected, it may take slightly longer for copies to make since the machine selects the paper after scanning the original.

Manual paper select

- 1 Select the paper roll 1, paper roll 2, paper roll 3 (option), or bypass tray.

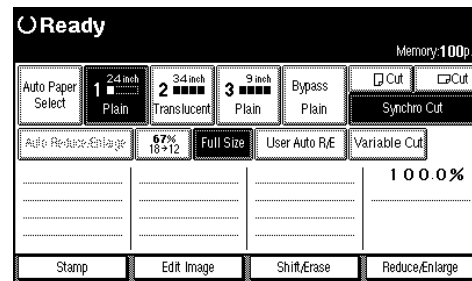

Auto Reduce/Enlarge

The machine can choose an appropriate magnification based on the paper and original sizes you select.

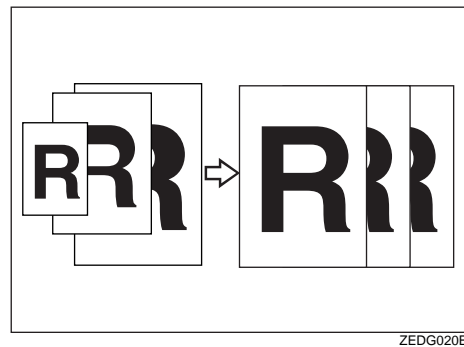

Limitation

- ❑ The machine selects one of the following ratios:
 - Metric version
400%, 283%, 200%, 141%, 100%, 71%, 50%, 35%, 25%
 - Inch version

Engineering	400%, 259%, 200%, 129%, 100%, 65%, 50%, 32%, 25%
Architecture	400%, 267%, 200%, 133%, 100%, 67%, 50%, 33%, 25%

Note

- ❑ This is useful when you want to copy different size originals to the same size paper.

Reference

⇒ P.160 "Magnification Ratio Chart"

1 Press the [Auto Reduce/Enlarge] key.

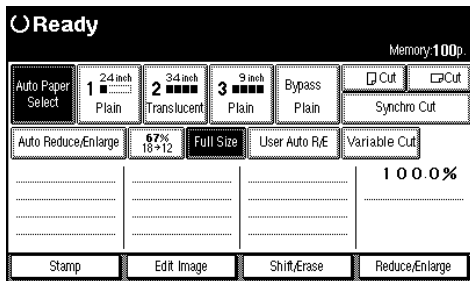

2 Select the paper roll 1, paper roll 2, or paper roll 3 (option).

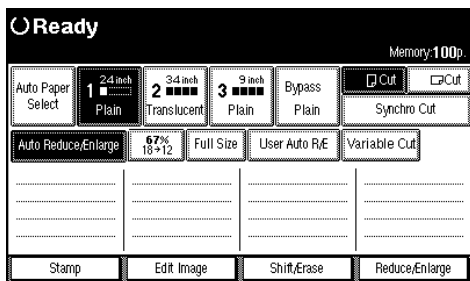

User Auto Reduce/Enlarge

Copies to a selected copy size for each original size.

When the original is set, the machine automatically enlarges or reduces the image to fit the size of the copy paper.

Preparation

You can select the following combinations.

◆ Metric version

Original Size	Copy size
A0	A0, A1, A2, A3, A4
A1	A0, A1, A2, A3, A4
A2	A0, A1, A2, A3, A4
A3	A0, A1, A2, A3, A4
A4	A0, A1, A2, A3, A4

◆ Inch version

	Original size	Copy size
Engineering	E(34"×44")	E(34"×44"), D(22"×34"), C(17"×22"), B(11"×17"), A(8 1/2"×11")
	D(22"×34")	
	C(17"×22")	
	B(11"×17")	
Architecture	E(36"×48")	E(36"×48"), D(24"×36"), C(18"×24"), B(12"×18"), A(9"×12")
	D(24"×36")	
	C(18"×24")	
	B(12"×18")	

Note

- ❑ The default setting is to copy to the same size paper (full-size). To change the combination, use User Auto Reduce/Enlarge. See P.132 "User Auto Reduce/Enlarge"
- ❑ You can specify whether the original should be processed as a or original. See P.132 "User Auto R/E Original Size Detect"

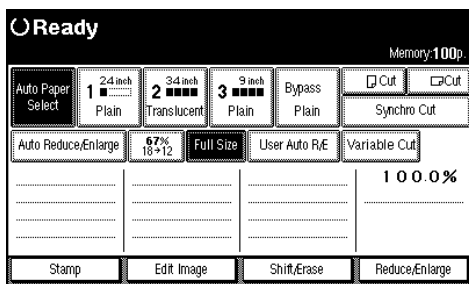
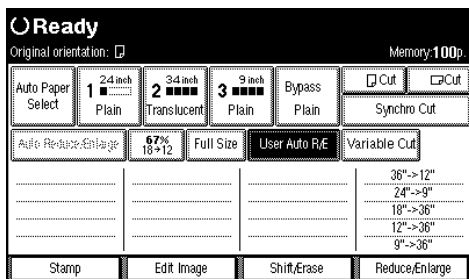
2**1** Press the [User Auto R/E] key.**2** Check that the combination selected for User Auto Reduce/Enlarge is the one you want.

Copying from the Bypass Tray

Use the bypass tray to copy paper sizes that cannot be loaded on the paper rolls, or for cut sheet paper.

2

Preparation

When copying from the bypass tray, you can make several copies for an original. To make several copies, place the next paper on the bypass tray after previous paper has been fed into the machine. When copying the following original types, place the original and then load paper in the bypass tray.

Limitation

- You cannot use Interrupt Copy after setting the original.
- The maximum length for long length is 2,000mm, 78.8".
- The width for paper in the bypass tray is 210 – 914mm, 8.3" – 36".
- Do not copy on both sides of the paper.
- Do not use paper which has been copied or printed on.
- You cannot use Job Preset. If you scan several originals, the last original will be used.

Reference

For details about the paper type, direction, and number of sheets that can be loaded in the bypass tray, see P.16 "Copy Paper"

1 Press the [Bypass] key.

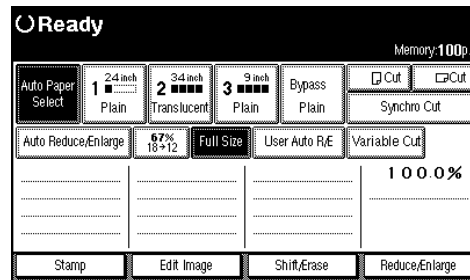

2 Make sure that the type of paper selected for the [Bypass] key is displayed.

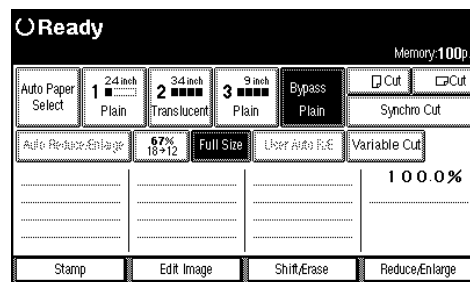

Note

- You can specify the paper type for the bypass tray. See "Bypass Tray Paper Type" in the System Settings manual.

3 Make your desired settings.

Reference

For details, see explanations of each function.

4 Place you original and scan it.

Reference

P.31 "Setting Originals"

- 5** Adjust the paper guides for the bypass tray to the size of the paper.

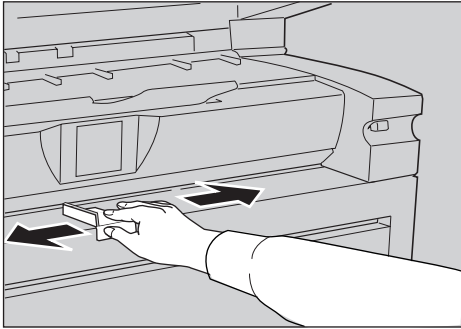

ZEDH170E

2

- 6** Load the paper in the bypass tray, with the surface to copied on to face up.

The paper is automatically fed into the machine and copying starts.

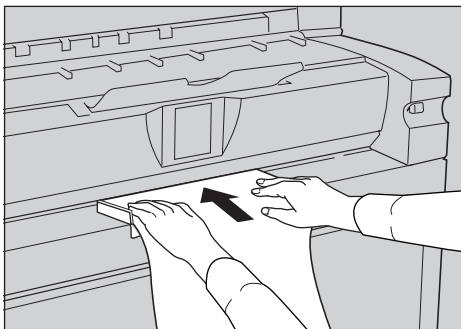

ZEDH200E

Important

- Place the paper after the original has completely scanned.
- Insert the paper evenly on both sides and support the paper with your hands until it is fed into the machine.

Note

- To make several copies, load an additional sheet of paper after each sheet has been fed into the machine.

2

Setting the Length of Copy Paper Cut

 **Preparation**

The following paper cut methods are available.

❖ **Synchro Cut**

Cuts the paper at the same length as the original.

If the copy is enlarged or reduced, the machine calculates the appropriate length for the magnification ration and cuts the paper.

❖ **Preset Cut**

Cuts the paper at a preset size, regardless of the size of the original. You can use this to copy different sized originals to the same size.

❖ **Variable Cut**

The paper is cut to the size entered.

 **Important**

- Except for Synchro Cut, the paper is cut regardless of the size of the original.
- The maximum length paper copy depend on the paper type and width.

❖ **Metric version**

Paper width	841 mm	594 mm	420 mm	297 mm
Paper type				
Plain	6000 mm	3600 mm	2000 mm	2000 mm
Translucent paper	3600 mm	3600 mm	2000 mm	2000 mm
Film				

❖ **Inch version (Engineering)**

Paper width	34"	22"	17"	11"
Paper type				
Plain	236"	142"	78.7"	78.7"
Translucent paper (vellum)	142"	142"	78.7"	78.7"
Film				

❖ **Inch version (Architecture)**

Paper width	36"	24"	18"	12"
Paper type				
Plain	236"	142"	78.7"	78.7"
Translucent paper (vellum)	142"	142"	78.7"	78.7"
Film				

Synchro Cut

 **Note**

- When using Synchro Cut the paper can be cut from 200 to 6000 mm (7.9" to 236") (from 250 to 6000 mm (9.8" to 236") for paper roll 3).

 **Limitation**

- Depending on the original length and the paper, the paper may be cut error.

1 Press the [Synchro Cut] key.

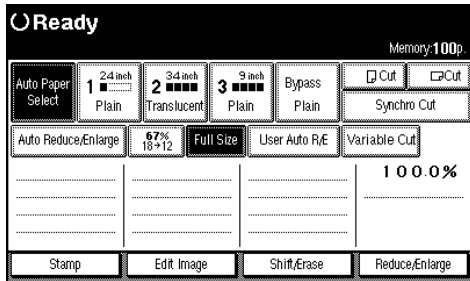

2 Select the paper roll 1, paper roll 2, or paper roll 3 (option).

Preset Cut

1 Select the paper roll 1, paper roll 2, or paper roll 3 (option).

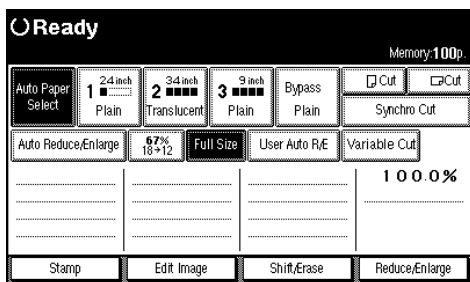

2 Select the Preset Cut size.

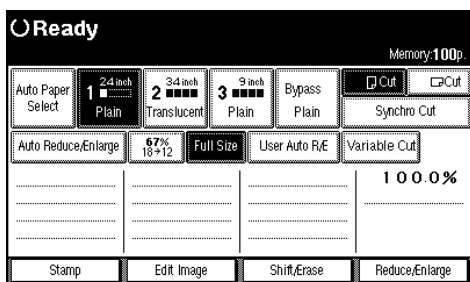

Note

- The preset cut length is divided into some types. Depending on the roll paper width, it is cut in the following standard length.

❖ **Metric version**

Roll paper width	Preset length	Paper size and direction
841mm	1,189mm	A0
	594mm	A1
594mm	841mm	A1
	420mm	A2
420mm	594mm	A2
	297mm	A3
297mm	420mm	A3
	210mm	A4
210mm	297mm	A4
	—	—

2

❖ **Inch version (Engineering)**

Roll paper width	Preset length	Paper size and direction
34"	44"	E
	22"	D
22"	34"	D
	17"	C
17"	22"	C
	11"	B
11"	17"	B
	8 ¹ / ₂ "	A
8 ¹ / ₂ "	11"	A
	—	—

2

◆ Inch version (Architecture)

Roll paper width	Preset length	Paper size and direction
36"	48"	E ↙
	24"	D ↙
24"	36"	D ↙
	18"	C ↙
18"	24"	C ↙
	12"	B ↙
12"	18"	B ↙
	9"	A ↙
9"	12"	A ↙
	—	—

Variable Cut

Note

- ❑ When using Variable Cut the paper can be cut from 210 to 6000mm (from 8.3" to 236") (from 250 to 6000mm (9.8" to 236") for Paper Roll 3.)

1 Select the paper roll 1, paper roll 2, or paper roll 3 (option).

2 Press the [Variable Cut] key.

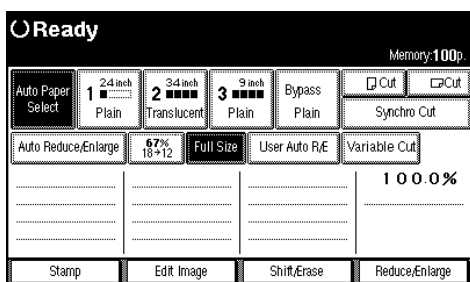

3 Enter the length with the number keys, and then press the [#] or [OK] key.

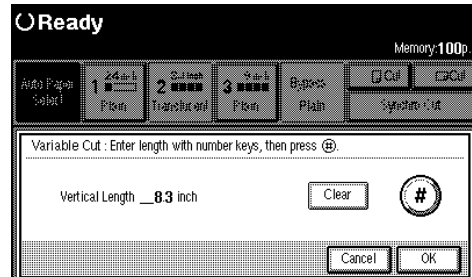

Note

- ❑ To change the value, press the [Clear] key and enter the new value.
- ❑ If you do not want to use Variable Cut, press the [Cancel] key.

If you enter a length for Variable Cut, the length is displayed on the screen.

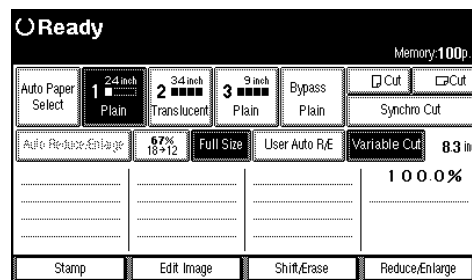

Sort/Rotate Sort

Copies can be assembled as sets in sequential order.

Preparation

The following sort options are available. You can also specify whether the copies in the sets are arranged first to last, or last to first.

Sort

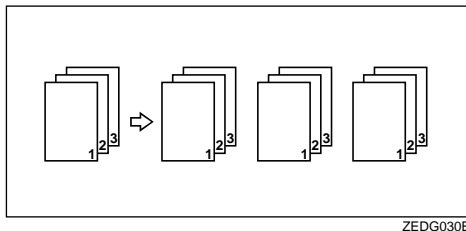

ZEDG030E

Rotate Sort

Alternate sets are rotated  and delivered to the output tray.

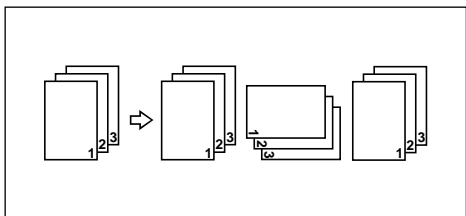

ZEDG040E

Limitation

- You cannot select Sort for Job Pre-set copy jobs.
- You can use the following paper sizes with Rotate Sort.

Metric version

- 297mm × 210mm
- 420mm × 297mm
- 594mm × 420mm

Inch version (Engineering)

- 11" × 8¹/₂"
- 17" × 11"
- 22" × 17"

Inch version (Architecture)

- 12" × 9"
- 18" × 12"
- 24" × 18"

- When using Rotate Sort, make sure that the original and paper image sizes are the same. For example, when using A1(D) original, you can select A2(C) size paper using reduce the original size to 70%.
- The number of originals that can be scanned for Sort and Rotate Sort is as follows:

	Standard	Optional HDD installed
A0(E) *1	—	more than 50 sheets
A1(D) *1	2 sheets	more than 100 sheets
A2(C)	4 sheets	more than 100 sheets
A3(B)	8 sheets	more than 100 sheets
A4(A)	16 sheets	more than 100 sheets

*1 Sort only. You cannot use A0(E) and A1(D) with Rotate sort.

Note

- After all the originals have been scanned, press the **[Finish]** key to start copying. You can change this setting. See P.129 "Sort Copy Setting"

2

Reference

Once you start scanning the originals, the memory indicator display starts to decrease. You can change the memory indicator display to use a number of pages, or a percentage. See P.128 "Memory Status Display"

1 Press the [Sort] or [Rotate Sort] key.

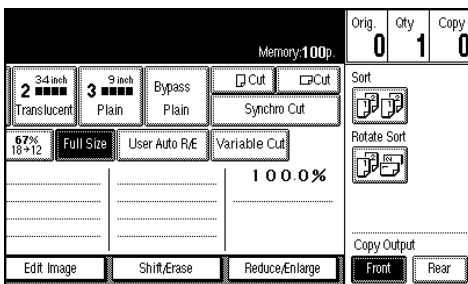

Displayed "Ready for Sort" on the screen.

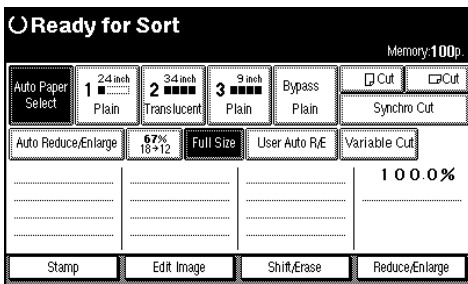

2 Make your desired settings.

Reference

For details, see explanations of each function.

3 Place your originals.

Reference

P.31 "Setting Originals"

After the originals have been scanned, the following message is displayed.

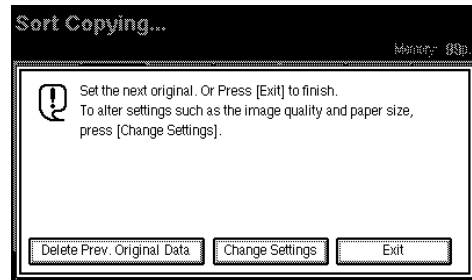

Note

- You can repeat the scanning procedure until all the originals have been scanned.
- To cancel Sort or Rotate Sort, press the **[Clear Modes/Energy Saver]** key.

4 After the last original has been scanned, press [Finish] key.

The machine starts copying.

Note

- After sorting has finished, if you change the paper roll setting in the Additional Copy, the paper will be fed depend on Additional Copy setting, regardless of the original setting.

Program

You can store frequency used copy job settings in machine memory, and recall them for next use.

The Program function includes the following settings.

❖ Storing Your Settings

You can store settings you frequently use.

❖ Deleting A Program

You can delete a stored program.

❖ Recalling A Program

You can recall a stored program.

Note

- You can store up to 20 programs.
- You can only select paper roll as the paper source on the screen. You cannot store the paper type or size.
- If you store the settings in the program sheet, you can create a list. See P.157 "Program Record Sheet"
- Immediately after the machine is turned on, after Auto Reset, or after a reset, the settings are set to those stored in program No. 20. See P.126 "Initial Mode Set"
- The stored settings are stored even after the power is turned off, or the **[Clear Modes/Energy Saver]** key is pressed, they have not been deleted.

Storing Your Settings

1 Edit the copy settings so that all functions you want to store in this program are selected.

2 Press the **[Program]** key.

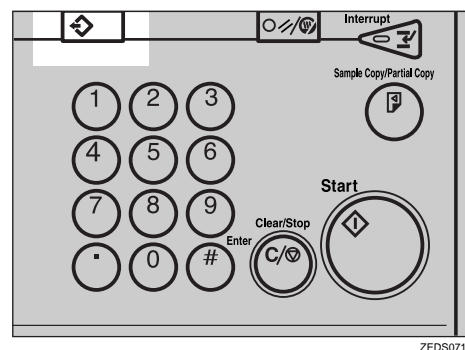

The Program screen is displayed.

3 Press the **[Store]** key.

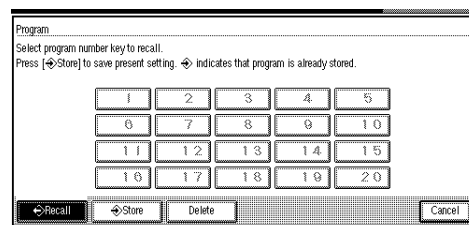

4 Press the program number you want to store.

When the settings are successfully stored, the  indicator appears.

Note

-  indicates that program is already stored.

2

2

If Settings Are Already Stored (Edit)

1 Check the settings in the stored program.

Note

To check the settings of the stored program, or recall the program. See P.54 "Recalling a Program"

2 Edit the settings in the stored program, 1 - 4.

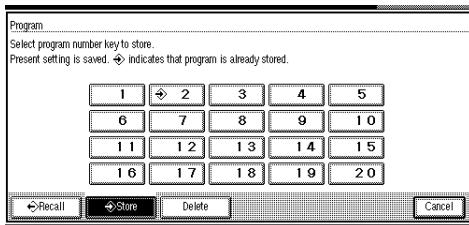

To overwrite the settings

1 Press the [Yes] key.

Important

When you overwrite the settings, the contents of the stored program are erased.

If you want to keep the settings

1 Press the [No] key.

3 Press the program number you want to delete.

4 Press the [Yes] key.

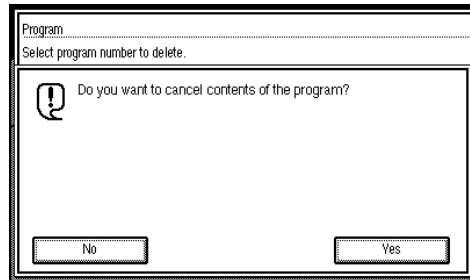

Note

To cancel the deletion, press the [No] key.

5 To delete another program, repeat steps 1 to 4.

Recalling a Program

1 Press the [Program] key.

2 Press the [Recall] key.

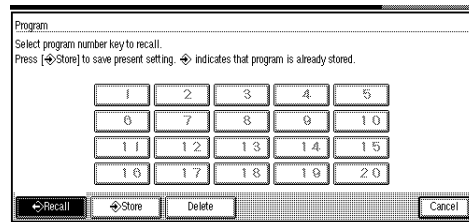

3 Press the program number you want to recall.

Note

Only programs with a double arrow icon are already stored.

Deleting a Program

1 Press the [Program] key.

The Program screen is displayed.

2 Press the [Delete] key.

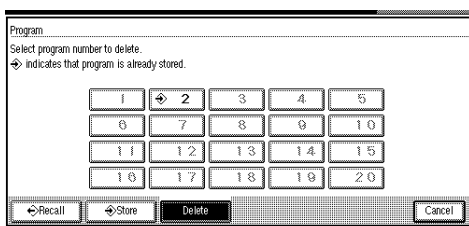

Other Functions

Energy Saver Mode

If you do not operate the machine for a certain period after copying, or when you press and hold the **【Clear Modes/Energy Saver】** key for more than two second, the display disappears and the machine enters Energy Saver mode. When you press the **【Clear Modes/Energy Saver】** key again, the machine returns to the ready condition.

In Energy Saver mode, the machine uses less power consumption. The Energy Saver mode makes a two-step reduction in power consumption: one for the period up to the time set for Low Power mode, the other for the period after that time.

Reference

For Panel Off Timer setting, see "Panel Off Timer" in the "System Settings" manual.

For Energy Saver Timer setting, see "Energy Saver Timer" in the "System Settings" manual.

Auto Start

If you make the settings and scan the originals while the message "Ready to Copy" is displayed, your copies will be made as soon as warm-up finishes.

User Codes

If the machine is set to use the User Code function, operators must input their user codes before the machine can be operated. The machine keeps count of the number of copies made under each user code.

Note

- When the machine is set for user codes, the machine will prompt you for your user codes after the operation switch is turned on or the Auto Reset comes into effect.
- To force the machine to display the user code entry screen, press the **【Clear/Stop】** key while pressing the **【Clear Modes/Energy Saver】** key.

Reference

For user code settings, see "User Code Access" in the "System Settings" manual.

For details on storing, changing, or deleting user codes, see P.141 "Program/Change/Delete, User Code".

Sample Copy

Makes a copy of the first part (0 – 250mm) of an original to a length of 210mm (8.3") (250mm (9.8") for paper roll 3.) This allows you check the copy settings before making a full copy.

2

Reference

You can select the default settings. See P.130 "Sample Copy Priority"

- 1 Press the **[Sample Copy/Partial Copy]** key.

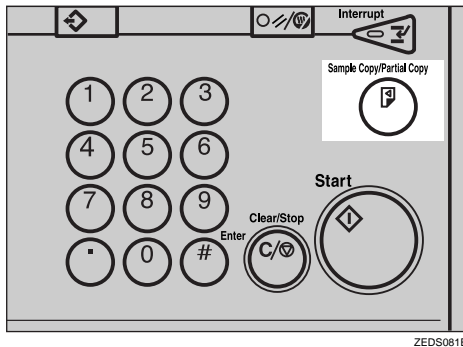

- 2 Press the **[Sample Copy]** key.

- 3 Press the **[Y]** key.

- 4 Enter the start position (Y) with the number keys.

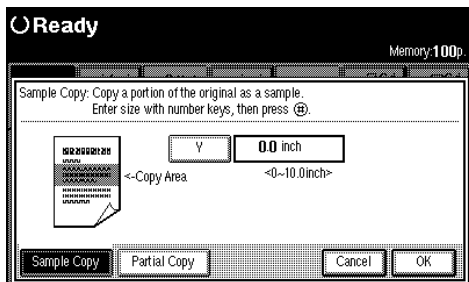

Note

- To change the value entered, press the **[Clear/Stop]** key, and then enter the new value.

- 5 Press the **[OK]** key.

- 6 Make your desired settings.

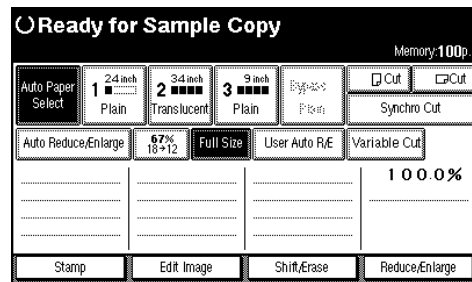

Reference

For details, see explanations of each function.

- 7 Place your originals.

The machine makes a 210mm (8.3") (250mm (9.8") for paper roll 3) copy.

Reference

⇒ P.31 "Setting Originals", P.130 "Sample Copy Priority"

Exiting Sample Copy

- 1 Press the **[Clear Modes/Energy Saver]** key.

Partial Copy

Copies only a specified portion of the original.

Reference

You can specify the start position (Y1) and the end position (Y2). See P.130 "Partial Copy Priority"

1 Press the **[Sample Copy/Partial Copy]** key.

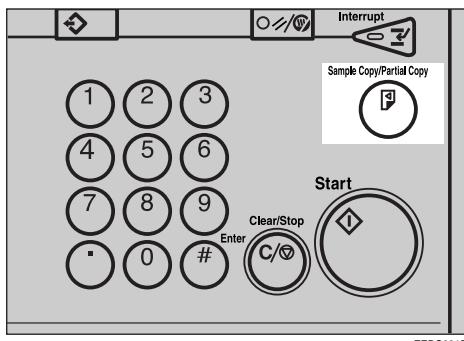

2 Press the **[Partial Copy]** key.

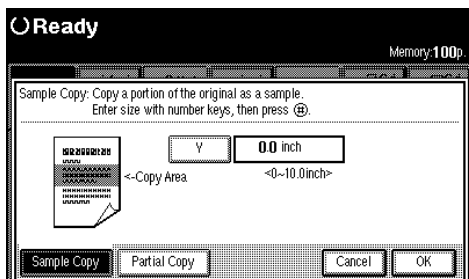

3 Press the **[Y2]** key, and then enter the scan end position with the number keys.

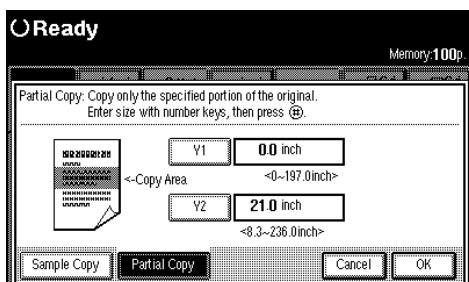

Note

- To change the value entered, press the **[Clear/Stop]** key and enter the new value.
- The minimum length for Partial Copy is 210mm (8.3") (250mm (9.8") for paper roll 3). Enter a value for Y2-Y1> that specifies a length of at least 210mm (8.3") (250mm (9.8") for paper roll 3).
- If the length specified by **[Y2]** and **[Y1]** is less than 210mm, the machine adjusts the start position based on the last number you entered.

4 Press the **[Y1]** key, and then enter the scan start position.

5 Press the **[OK]** key.

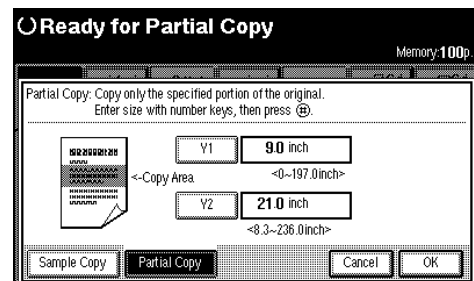

6 Make your desired settings.

Reference

For details, see explanations of each function.

7 Place your originals.

The machine makes a copy of the specified area.

Exiting Partial Copy

1 Press the **[Clear Modes/Energy Saver]** key.

Preset Reduce/Enlarge

You can select a preset ratio for copying. You can store up to three enlargement or reduction ratios of your own.

2

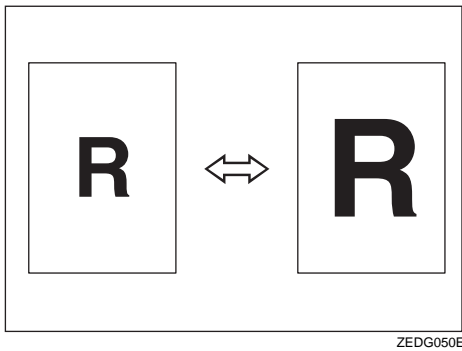

ZEDG050E

Preparation

You can select one of 8 present ratios (4 enlargement ratios, 4 reduction ratios).

Metric version

Enlargement Ratios: 141%, 200%, 283%, 400%
Reduction Ratios: 25%, 35%, 50%, 71%

Inch version

Engineering	Enlargement ratios: 129%, 200%, 259%, 400% Reduction Ratios: 25%, 32%, 50%, 65%
Architecture	Enlargement ratios: 133%, 200%, 267%, 400% Reduction Ratios: 25%, 33%, 50%, 67%

You can store up to three ratios of your own for ratios you frequently use, but which are not in the preset ratios. The ratios can be set in 0.1% steps (0.2% over 200%). See P.131 "User Reproduction Ratio"

You can specify the enlarge/reduce ratio to use when the power is turned on, after Auto Reset, or the **[Clear Modes/Energy Saver]** key has been pressed. See P.131 "Preset Reduce/Enlarge Priority"

Note

- Preset ratios are set by combining the original size and paper size.
- You can select a ratio regardless of the size of an original, copy paper or roll paper. With some ratios, parts of the image might not be copied or margins will appear on copies.

Reference

For details on the relation between the original and paper sizes for preset ratio, see the ratio table. See P.160 "Magnification Ratio Chart"

1 Press the [Reduce/Enlarge] key.

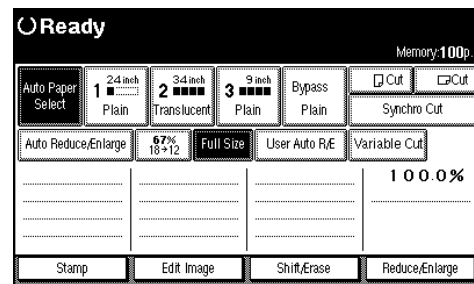

2 Select a ratio.

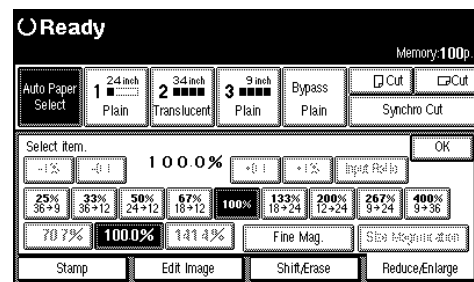

3 Press the [OK] key.

Zoom

You can change the magnification in 0.1% (or 1%) steps.

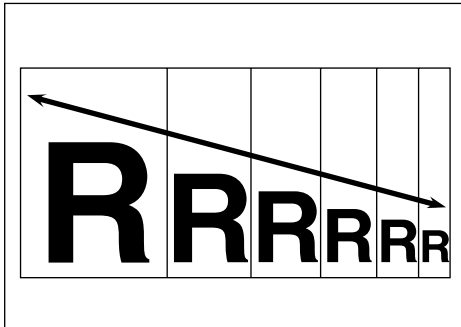

ZEDG060E

Preparation

You can set the ratio in the following ways.

- Using the number keys
- Selecting a ratio close to the one you want to set from Preset Reduce/Enlarge, and then press the **[-1%][+1%]** or **[-0.1][+0.1]** keys to adjust the ratio.

Limitation

- You cannot use Zoom if Auto Paper Select or User Auto Reduce/Enlarge are selected.

Note

- You can set the magnification ratio from 25.0 to 400.0%.
- To set the magnification ratio on screen, use the **[-1%]** or **[+1%]** key. To specify a decimal value, use the **[-0.1]** or **[+0.1]** key.
- For ratios 25.0 – 200.0% the steps are 0.1%, for ratios 200.0 – 400.0% the steps are 0.2%.
- You can select a ratio regardless of the size of an original, copy paper or roll paper. With some ratios, parts of the image might not be copied or margins will appear on copies.

1 Press the [Reduce/Enlarge] key.

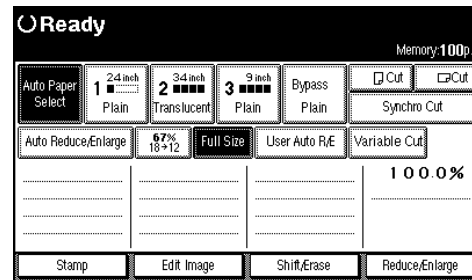

2

When using the Number keys

1 Press the [Input Ratio] key.

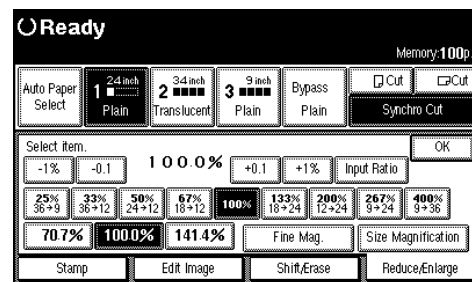

2 Enter the desired ratio with the number keys.

Note

- Use the **[.]** key to enter a decimal point.

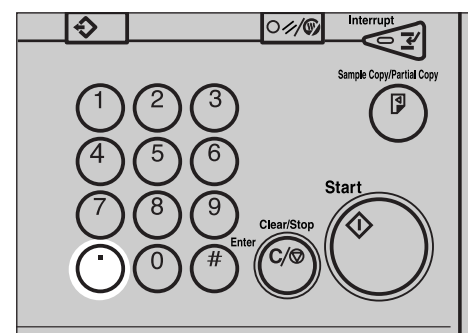

ZEDS091E

To change the value, press the **[Clear/Stop]** key, and then enter the new value.

3 Press the [#] key.

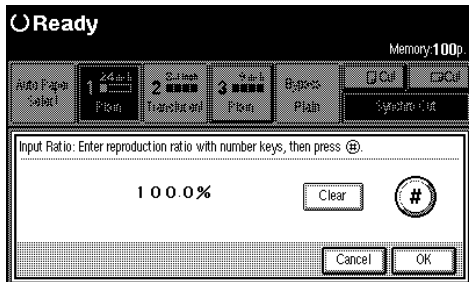

2

Selecting a ratio from the preset ratios, and then use the [-1%][+1%], or [-0.1][+0.1] keys to adjust it

- 1** Select a ratio.
- 2** Press the [-1%][+1%] or [-0.1][+0.1] keys to set the ratio.

Note

- Press the [-0.1] or [+0.1] key to adjust the ratio in 0.1% steps.
- If you make a mistake, press [-1%], [-0.1], [+0.1] and [+1%] key to readjust the ratio.

2 Press the [OK] key.

Fine Magnification

Paper can expand or shrink be affected, which can result in copies where size of the original and the copy do not match (such as under humid condition). This function uses the measurements of the original and the copy to calculate a ratio to produce copies that are close to actual size.

Note

- ❑ Fine Magnification is used for originals that have already been scanned. If you want to perform fine magnification corrections to paper that has stretched due to the type of paper or exposure to humid conditions, see "Fine Magnification: Copier" in the System Settings manual.
- ❑ Set the correction ratio after measuring the length and width of the original and the copy.

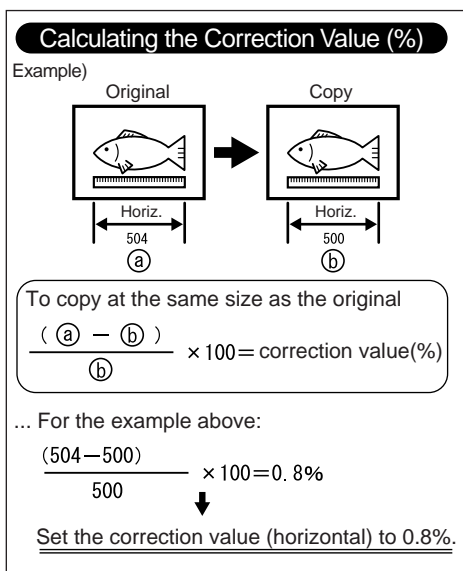

- ❑ When Fine Magnification is selected, depending on the pattern of original, moire patterns may be noticeable or the image quality may deteriorate.

1 Press the [Reduce/Enlarge] key.

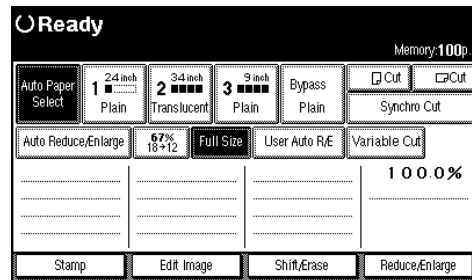

2

2 Press the [Fine Mag.] key.

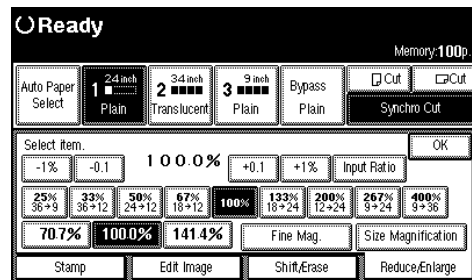

3 Select the paper type you want to correct, then adjust the horizontal and vertical ratio using the [-] and [+] keys.

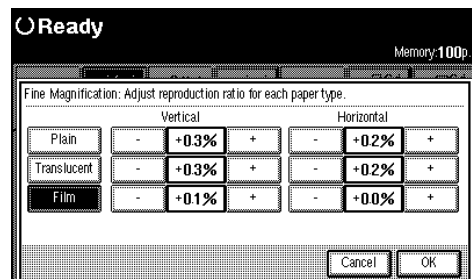

Note

- ❑ If you make a mistake, press the [Cancel] key, and then repeat the procedure again.

4 Press the [OK] key.

After you have set the correction values, they are displayed on the screen.

2

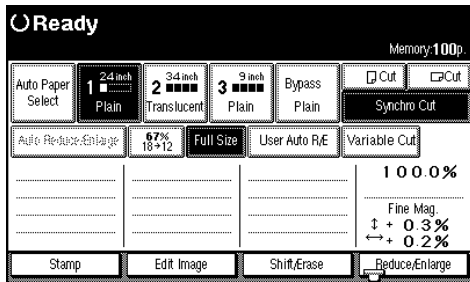

Note

- The settings also appear in "Fine Magnification: Copier" settings in the System Settings manual. If the settings are adjusted in System Settings and via the screen, the resulting setting will be a value that satisfies both.

Size Magnification

You can calculate a ratio from the lengths of the original and copy for enlarging or reducing the copy.

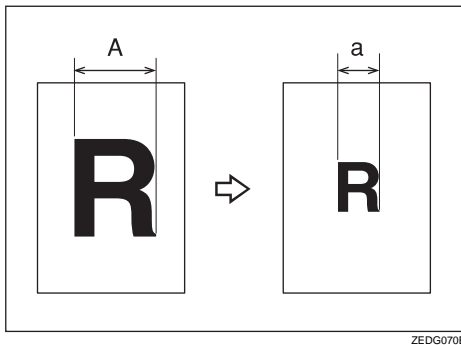

Preparation

Measure and specify the lengths of the original and copy by comparing "A" with "a".

The enlargement or reduction ratio is automatically calculated, eliminating the need to calculate the ratio yourself.

Limitation

- The ratio is selected from within the range of 25.0% – 400.0%.
- If the calculated ratio is less than 25%, the ratio is set to 25.0%, if it is more than 400%, it is set to 400.0%.
- You cannot use Size Magnification if Auto Paper Select is selected.

1 Press the [Reduce/Enlarge] key.

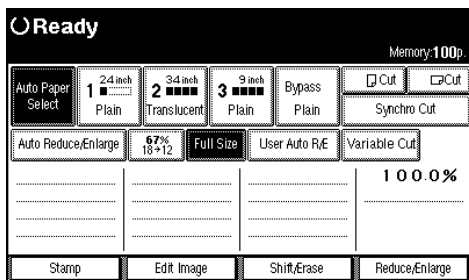

2 Press the [Size Magnification] key

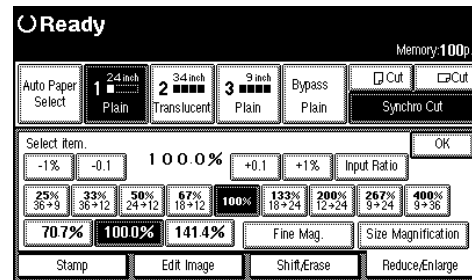

3 Enter the length of the original with the number keys, and then press the [#] key.

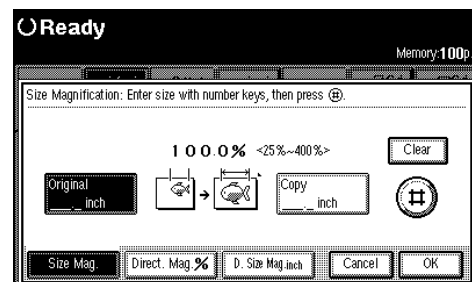

Note

- To change the value, press the [Clear] key, and then enter the new value.

4 Press the [Copy__mm (inch)] key on the screen and then enter the copy length with the number keys. Then press the [#] key.

Note

- To change the value, press the [Clear] key, and then enter the new value.

5 Press the [OK] key.

2

Directional Magnification (%)

Copies can be reduced or enlarged at different magnifications horizontally and vertically.

2

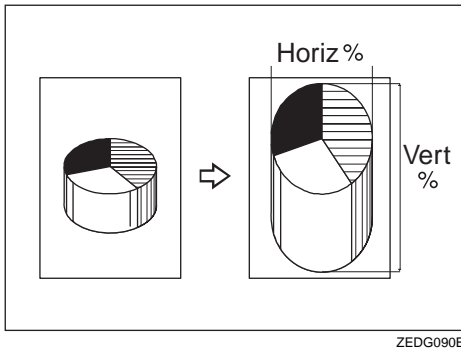

ZEDG090E

Preparation

You can set the ratio in the following ways.

- **[Number Keys]**
Using the number keys
- **[+/- keys]**
Using the [-] or [+] keys

You can set the ratio from 25.0 to 400.0%.

For ratios 25.0 – 200.0%, the steps are 0.1%, for ratios 200.0 – 400.0%, the steps are 0.2%.

Limitation

- ☐ You cannot use Directional Magnification (%) if Auto Paper Select is selected.

1 Press the [Reduce/Enlarge] key.

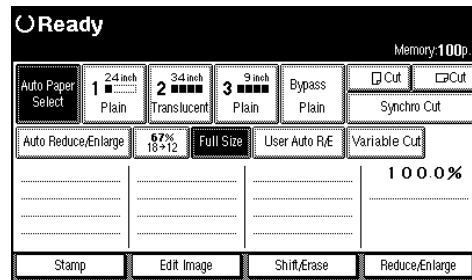

2 Press the [Size Magnification] key.

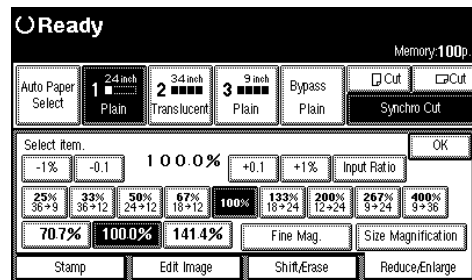

3 Press the [Direct. Mag%] key.

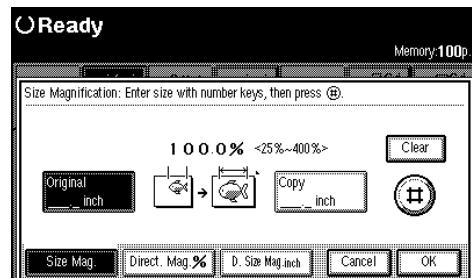

4 Press the [Horizontal] or [Vertical] key.

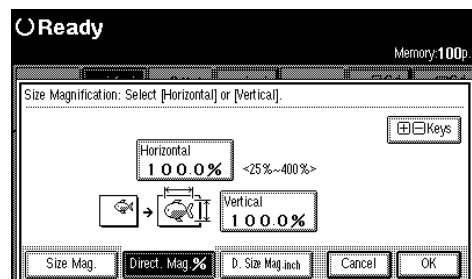

- 5 Enter the horizontal or vertical ratio with the number keys, and then press the [#] key.

Note

- Use the [.] key to enter a decimal point.

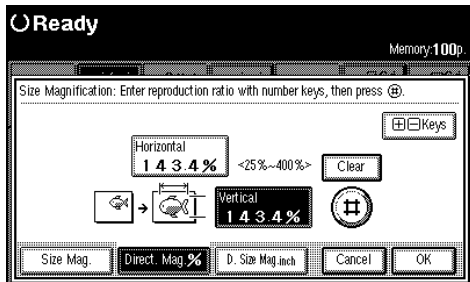

- To change the value, press the [Clear] key, and then enter the new value.

Using [-1%][+1%][-0.1][+0.1] key

- 1 Press the [+/- keys] key.

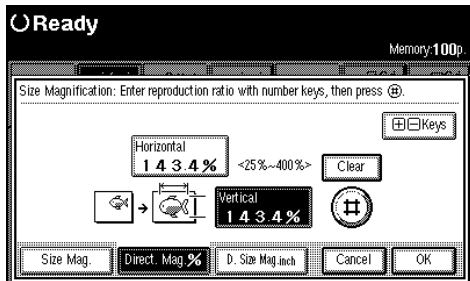

Note

- If a ratio has not been entered with either the [Horizontal] or [Vertical] keys, even if you press the [+/- keys], [-1%][+1%] [-0.1][+0.1] keys the value is not displayed.

- 2 Press the [-1%][+1%] or [-0.1][+0.1] keys to set the vertical ratio.

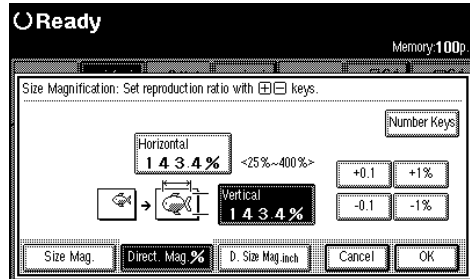

2

- 3 Press the [Vertical] key.
- 4 Press the [-1%][+1%] or [-0.1][+0.1] keys to set the vertical resolution.

- 6 Press the [OK] key.

Directional Size Magnification (inch)

You can specify the length for the horizontal and vertical size separately. You can use this function to distort the image.

2

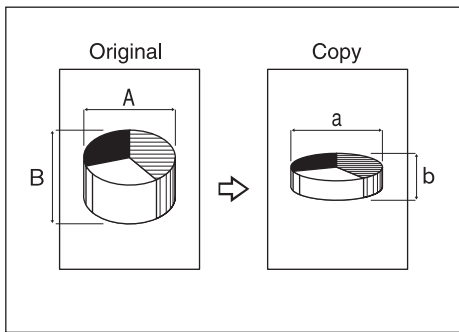

ZEDG100E

Preparation

Measure and specify the lengths of the original and copy by comparing "A" with "a".

You can set the ratio from 25.0 to 400.0%.

Limitation

- You cannot use Directional Size Magnification (inch) if Auto Paper Select is selected.

Note

- If the calculated ratio is less than 25%, the ratio is set to 25.0%, if it is more than 400%, it is set to 400.0%.

1 Press the [Reduce/Enlarge] key.

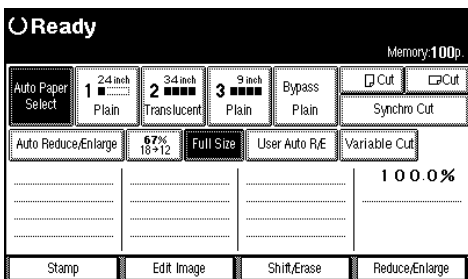

2 Press the [Size Magnification] key.

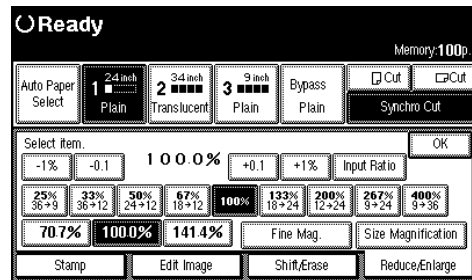

3 Press the [D. Size Mag.inch] key.

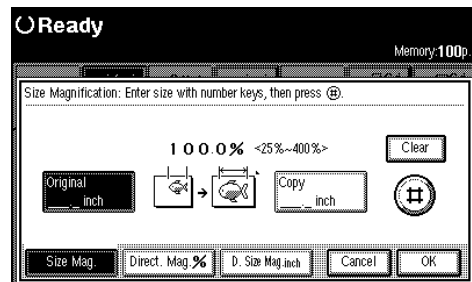

4 Enter the length for [Orig. Horiz.] with the number keys, and then press the [#] key.

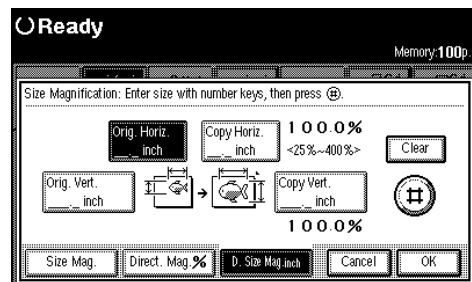

Note

- To change the value, press the [Clear] key, and then enter the new value.

5 Enter the length for [Copy Horiz.] with the number keys, and then press the [#] key.

- 6** Enter the length for [Orig. Vert.] with the number keys, and then press the [#] key.
- 7** Enter the length for [Copy Vert.] with the number keys, and then press the [#] key.

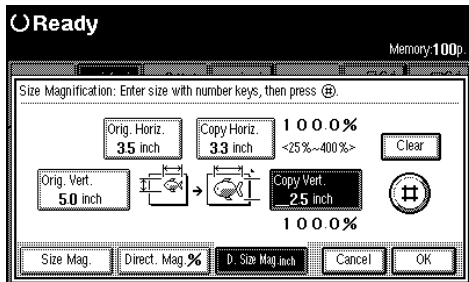

2

 **Note**

- To change one of the lengths, press the length you want to change, and then re-enter the number.

- 8** Press the [OK] key.

Margin Adjustment

When Synchro Cut is selected, you can create a margin for the leading edge and trailing edge of the original, and cut unnecessary parts of the copy.

2

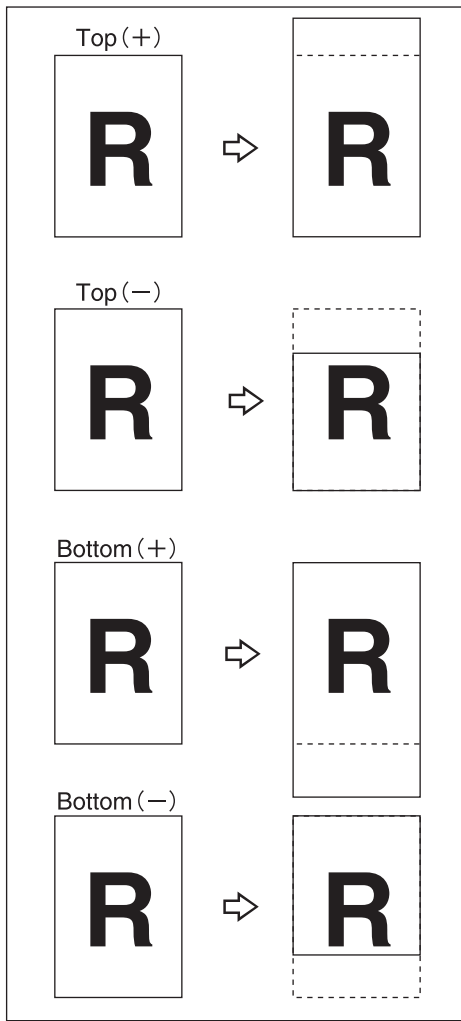

Preparation

You can select the following types of margin for this function.

- Top (+): Creates a margin for the leading edge of the original (top of the copy).
- Top (-): Reduces the margin for the leading edge of the original (top of the copy.)
- Bottom (+): Creates a margin for the trailing edge of the original (bottom of the copy.)
- Bottom (-): reduces the margin for the trailing edge of the original (bottom of the copy.)

You can set the margin from -200 to +200mm, in steps of 1mm (from -7.8" to 7.8", in steps of 0.1").

The default margin setting is 20mm, 2.0". You can change this default setting. See P.133 "Margin Adjustment Priority"

Press the top **[+][-]** and bottom **[+][-]** keys to set the margins.

The copy length will be the specified length plus or minus the amount of the margin.

1 Press the [Shift/Erase] key.

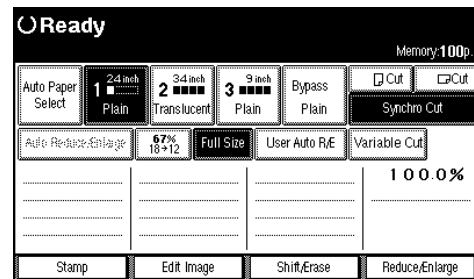

2 Press the [Margin Adjustment] key.

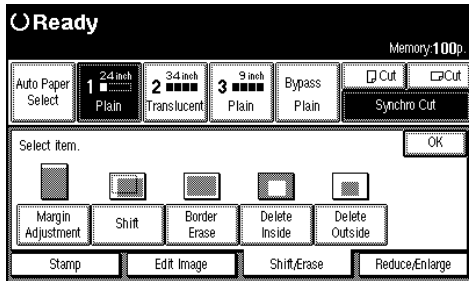

2

3 Press the [Top] or [Bottom] key.

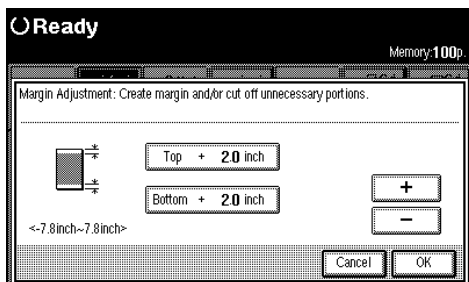

4 Use the [-] or [+] keys to set the top and bottom margins.

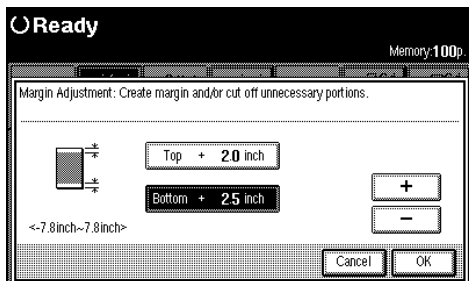

Note

- If you set a minus margin that would make the size of the copy less than 210mm (8.3") (250mm (9.8")for Paper Roll 3), the paper will be cut at 210mm (8.3").

5 Press the [OK] key.

Shift

Moves (shifts) the copy image up, down, left, or right to create a margin.

2

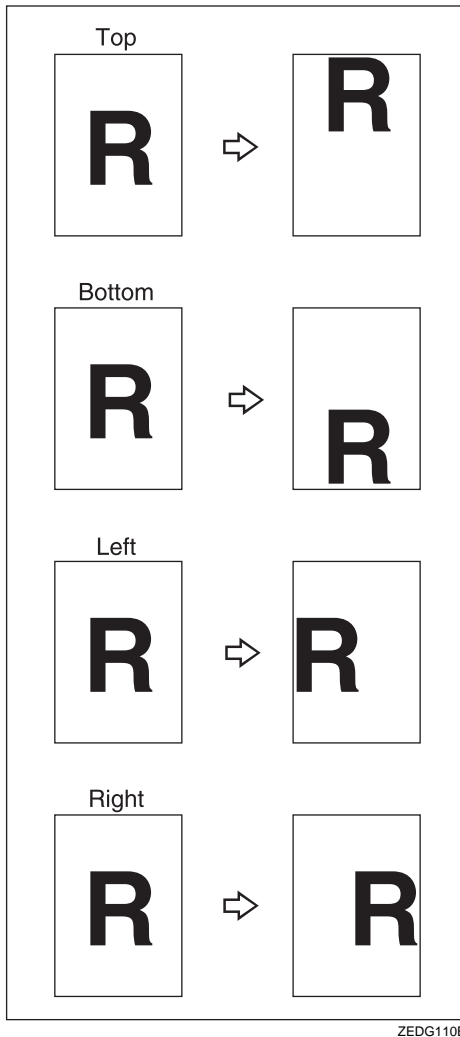

Preparation

You can select the following types of margin for this function.

- [↑] key (Top): Shifts the image towards the leading edge of the original (top of the copy.)
- [↓] key (Bottom): Shifts the image towards the trailing edge of the original (bottom of the copy.)

- [←] key (Left): Shifts the image towards the left of the original.
- [→] key (Right): Shifts the image towards the right of the original.

You can shift the image from 0 to 200mm in 1mm steps (0 to 7.8" in 0.1" steps).

The default setting is 20mm, 2.0". You can change this setting. See P.133 "Shift Image Area Priority"

You can also shift the image in a combination of up/down and left/right.

Limitation

- When using the print and shift settings, the print position is moved in the direction of the shift setting.
- You can use the Shift function for copy sizes up to A0 (E).

1 Press the [Shift/Eraser] key.

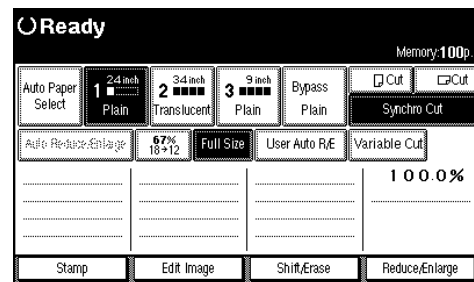

2 Press the [Shift] key.

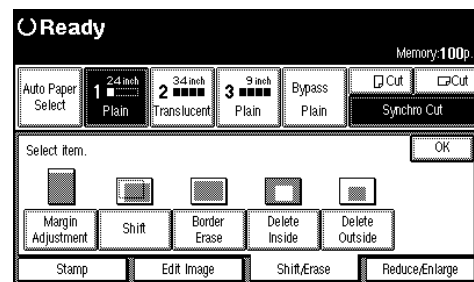

Creating a top or bottom margin

- 1 Press the [↑] or [↓] keys to set the length of the shift amount.

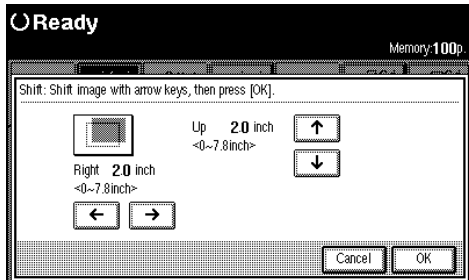

2

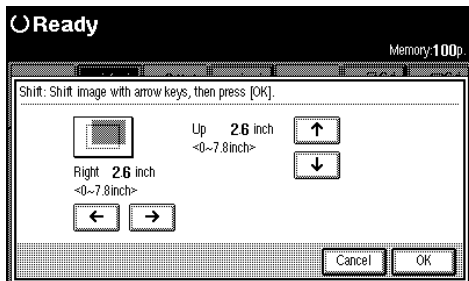

Creating a left or right margin

- 1 Press the [←] or [→] keys to set the length of the shift amount.

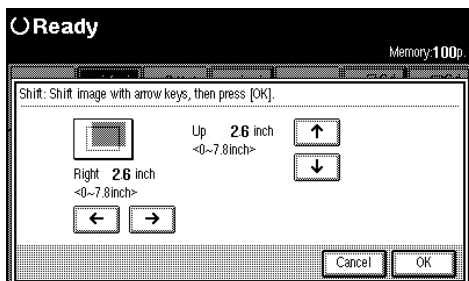
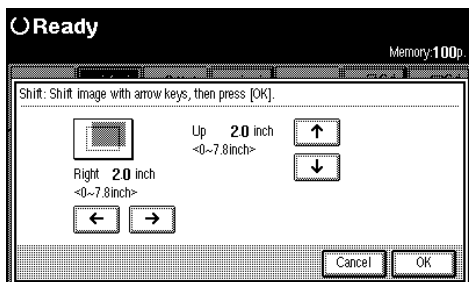

- 3 Press the [OK] key.

Border Erase

Erases the rim area of the original image.

2

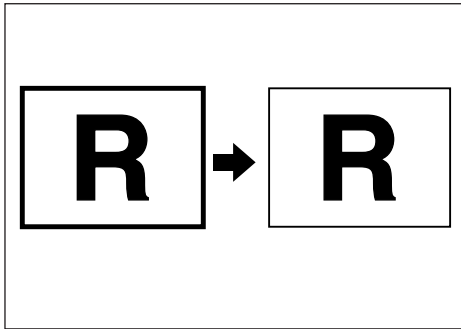

ZEDX080E

Preparation

The default border erase setting is 10mm, 0.4". You can change this setting. See P.133 "Border Erase Width Priority"

1 Press the [Shift/Eraser] key.

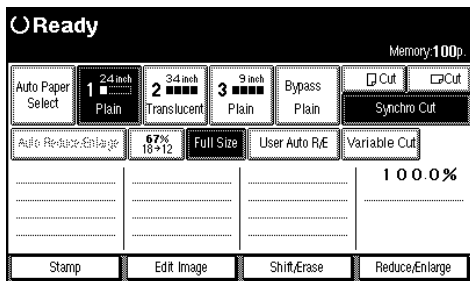

2 Press the [Border Erase] key.

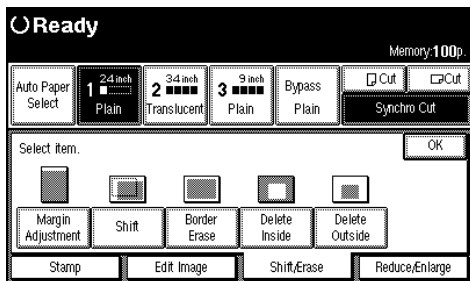

Setting border erase to same width

- 1 Press the [Same Width] key.
- 2 Press the [-] or [+] keys to set the Border Erase width, and then press the [OK] key.

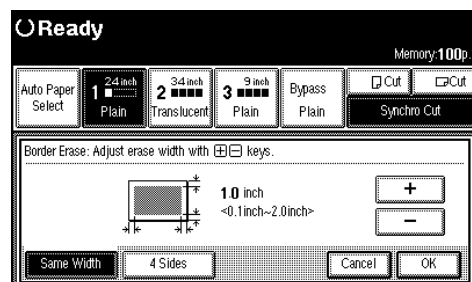

Setting border erase to separate widths

- 1 Press the [4 Sides] key.

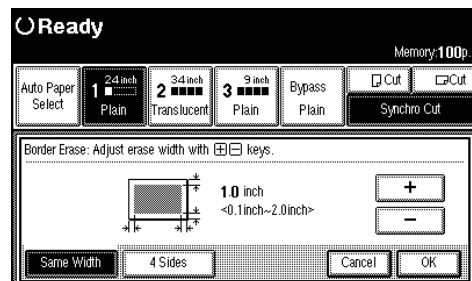

- 2 Press the [Top], [Bottom], [Left] and [Right] keys to select the erase rim area, and set the Border Erase width using the [-] or [+] keys. Then press the [OK] key.

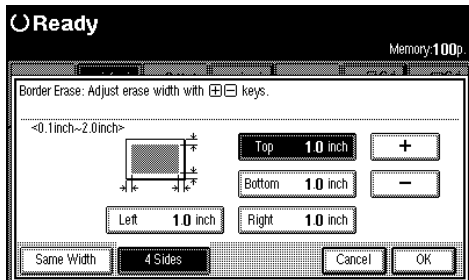

2

! Limitation

- When using the Border Erase function with other functions, see P.101 "Chart of Scan Sizes for Each Function".

Delete Inside

Copies the original while erasing parts inside a specified area.

2

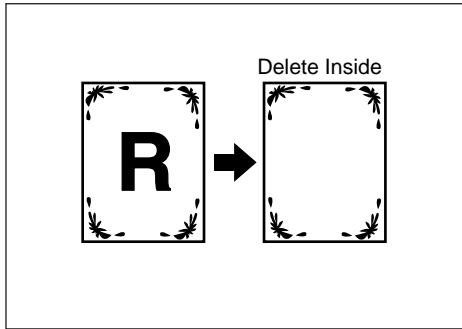

ZEDX010E

Limitation

- If the original is larger than A1, you can only erase one area (Metric version only).
- If the original is larger than C, you can only erase one area (Inch version only).

Note

- The area is specified by defining to two points for the top left of the original (X1, Y1) and two points for the size of the area (X2, Y2). Measure the area you want to specify before entering the area settings.

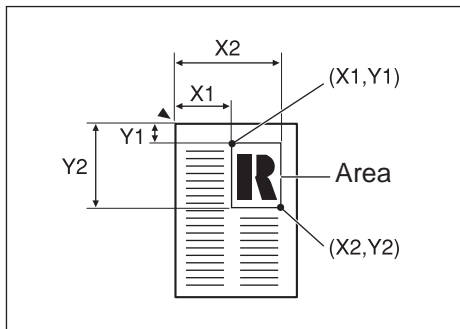

ZEDG140E

- When using this function with the magnification function, the actual setting will be the specified setting multiplied by the reproduction ratio.
- You can specify up to 5 areas.

1 Press the [Shift/Erase] key.

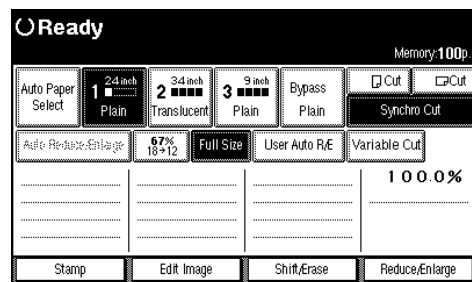

2 Press the [Delete Inside] key.

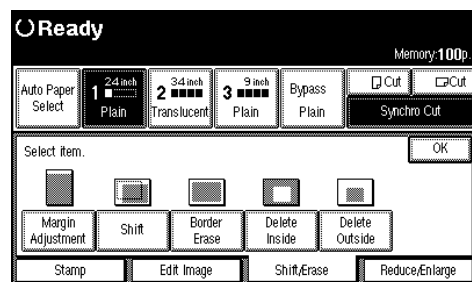

3 Press the [Y1], [Y2], [X1] and [X2] keys to select the delete position, and enter the values to specify the area, and then press the [#] key.

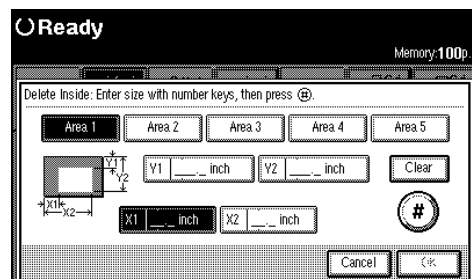

Note

- To change the value, press the **[Clear]** key, and then enter the new value.

- 4** To specify several areas, specify areas 1 – 5 in the same way.

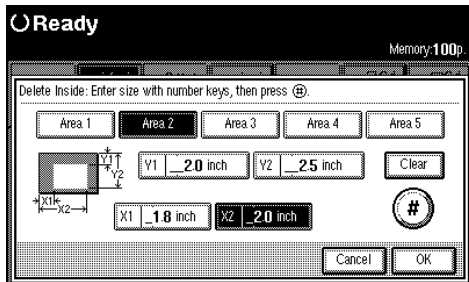

- 5** Press the **[OK]** key.

Delete Outside

Copies the original while erasing parts outside a specified area.

2

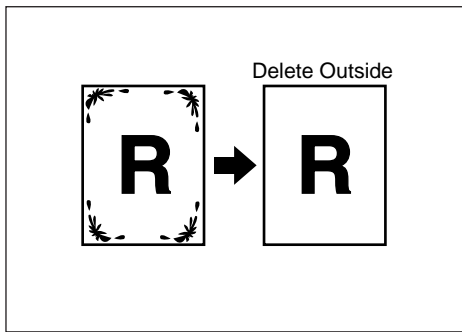

ZEDX020E

Limitation

- If the original is larger than A1, you can only specify one area (Metric version only).
- If the original is larger than C, you can only erase one area (Inch version only).

Note

- The area is specified by defining two points for the top left of the original (X1, Y1) and two points for the size of the area (X2, Y2). Measure the area you want to specify before entering the area settings.

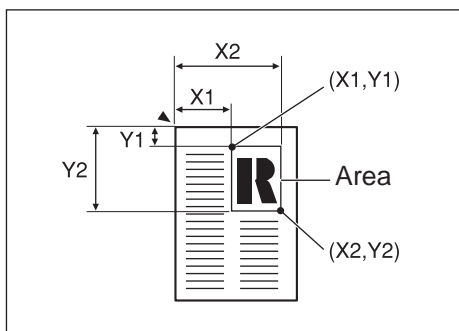

ZEDG140E

- When using this function with the magnification function, the actual setting will be the specified setting multiplied by the reproduction ratio.
- You can specify up to 5 areas.

1 Press the [Shift/Erase] key.

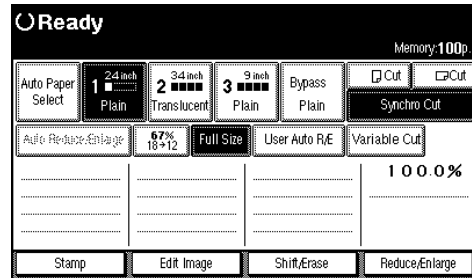

2 Press the [Delete Outside] key.

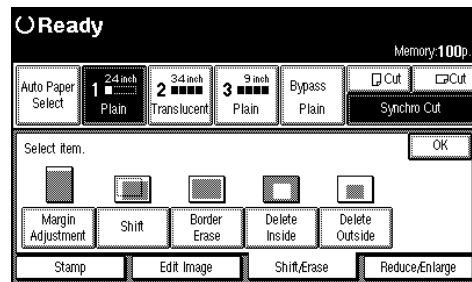

3 Press the [Y1], [Y2], [X1] and [X2] keys to select the delete position, and enter the values to specify the area, and then press the [#] key.

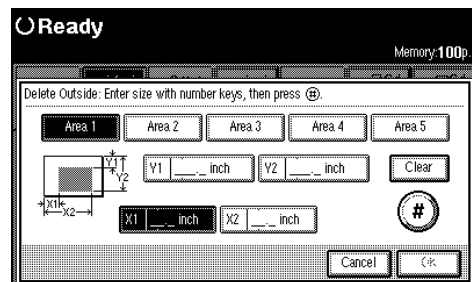

4 To specify several areas, specify areas 1 – 5 in the same way.

5 Press the [OK] key.

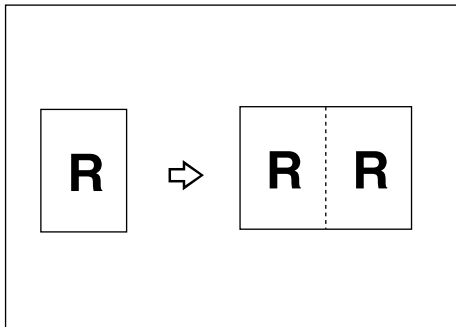

Double Copies

One original image is copied twice on to one copy as shown in the illustration.



ZEDG170E

Limitation

- ❑ You can copy an image up to A2 (C) in size with the Double Copies function . You can use a paper size up to A1 (D) .

Note

- ❑ You can erase the separation line between the two images. The default setting is Separation Line. See P.134 "Double Copies Separation Line"
- ❑ When using Double Copies, the paper size must be twice as large as the original (when **[Full size]** is selected). When using Reduce/Enlarge, consider the magnification ratio when selecting the paper size.

- 1** Press the **[Edit Image]** key.

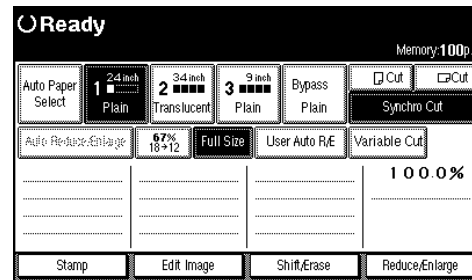

2

- 2** Press the **[Double Copies]** key.

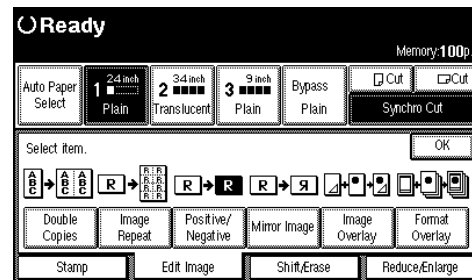

- 3** Press the **[OK]** key.

Image Repeat

The original image is copied repeatedly.

2

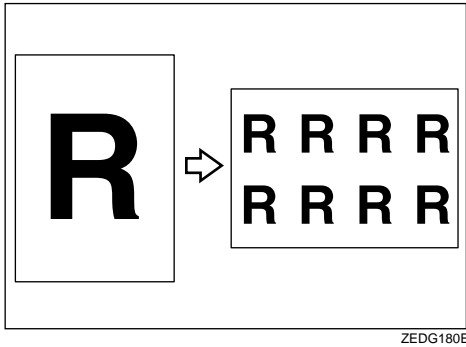

ZEDG180E

Preparation

The number of repeated images depends on the original size, copy paper size, and reproduction ratio.

- For example you can copy eight images of a A4 (A) original to A1 (D) size copy paper.

Limitation

- You cannot use the bypass tray.
- Depending on the paper size and the reproduction ratio, the repeated image may be cropped.
- You can use Image Repeat for copies with sizes up to A0(E).
- When Image repeat is selected, the maximum length for Variable Cut is 1,248mm, 48".
- When you have used Image Repeat with the stamp function, you cannot delete only the repeated image when using Additional Copy.

Note

- You can insert separation lines (Solid, Broken, Crop Marks) between repeated images. The default setting is None. See P.134 "Image Repeat Separation Line"
- When using Image Repeat with the Shift function, the composite image is repeated.
- When using Image Repeat with the Image Overlay function, the composite image is repeated.

1 Press the [Edit Image] key.

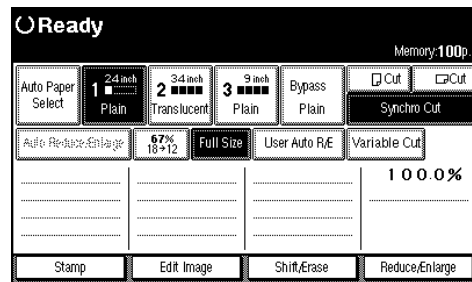

2 Press the [Image Repeat] key.

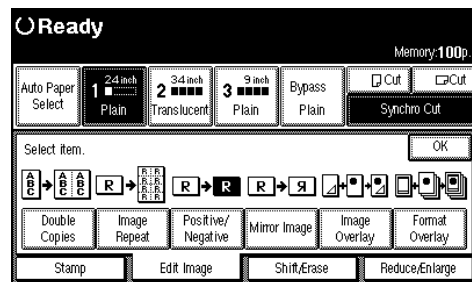

3 Press the [OK] key.

Positive/Negative

Black and white areas of the original are reversed.

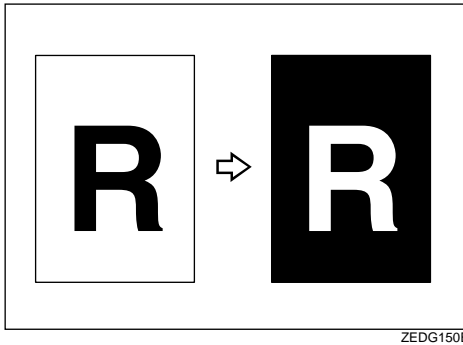

2

! Limitation

- You can use Positive/Negative for copies with sizes up to A0(E).

📝 Note

- When making continuous copies, the image density may deteriorate. See P.106 "If You Cannot Make Clear Copies"

1 Press the [Edit Image] key.

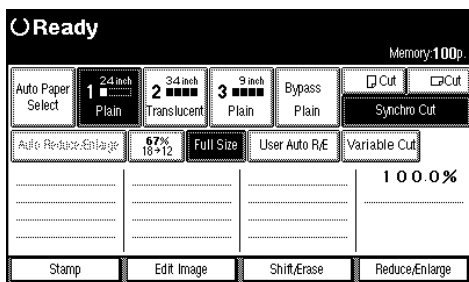

2 Press the [Positive/Negative] key.

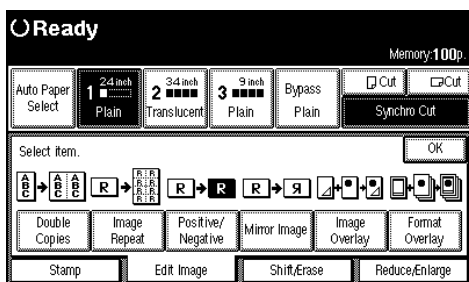

3 Press the [OK] key.

Mirror Image

The image is mirrored along the left/right axis, so that it appears as it would when viewed in a mirror.

2

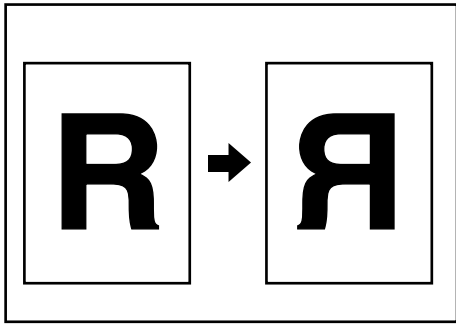

ZEDG160E

1 Press the [Edit Image] key.

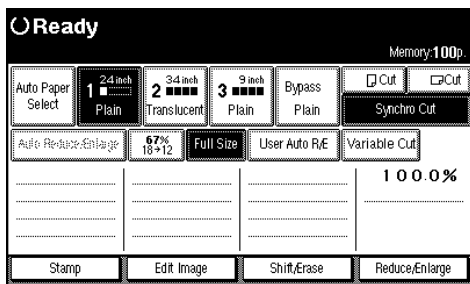

2 Press the [Mirror Image] key.

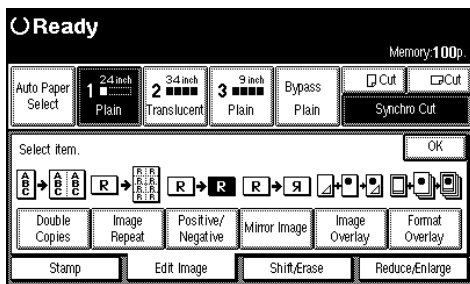

3 Press the [OK] key.

Image Overlay

Two originals are combined on one copy.

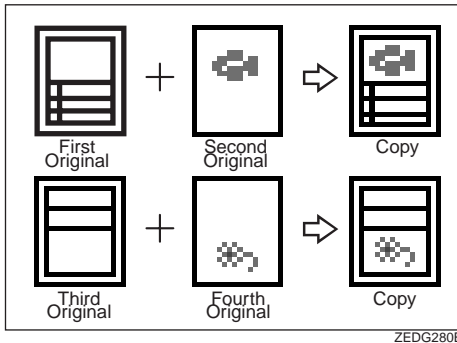

! Limitation

- For details on the combinations for background original and original for the composite image, see P.82 "Image Overlay Limitations".
- You cannot shift the position of the first or second original after the composite image has been created. If you want to change the position, move one of the originals. Use the composite copy itself as an original, or insert the originals in the carrier sheet.

📝 Note

- You cannot use the following functions after the originals have been scanned.
 - Copying From The Bypass Tray
 - Interrupt Copy

1 Press the [Edit Image] key.

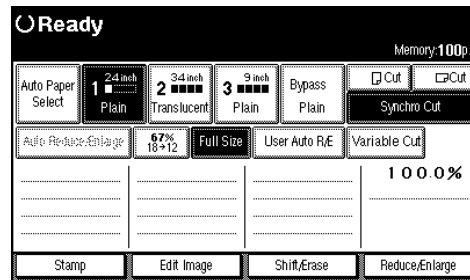

2

2 Press the [Image Overlay] key.

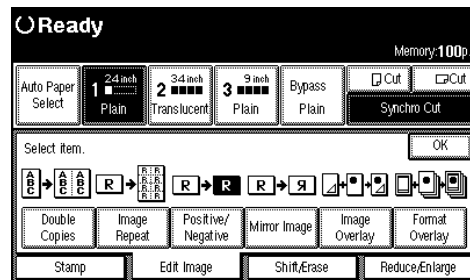

3 Press the [OK] key.

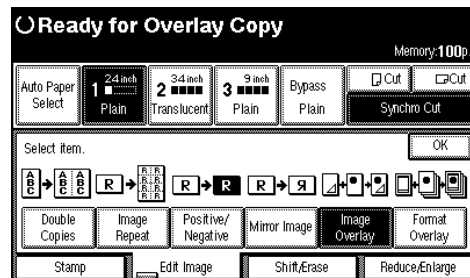

4 Make your desired settings.

🔍 Reference

For details, see explanations of each function.

5 Place the first original for the composite image.

2

6 Place the next original (to be overlaid on top of the first original) for the composite image.

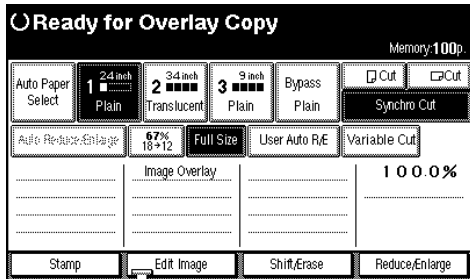

The composite copy is output to the copy output tray.

You can also add a third, fourth, fifth and sixth image.

Image Overlay Limitations

! Limitation

When using Image Overlay, you should use a second original that is larger than the first original. Because the background image (image of the first original) will be cut if Preset Cut is selected, and if the second original is smaller than the first original.

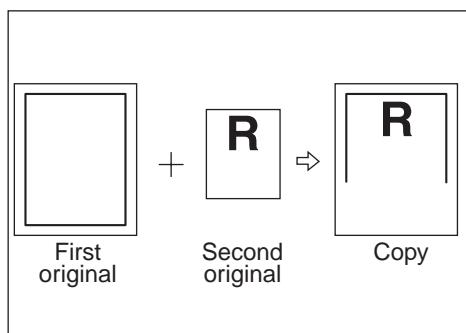

ZEDG130E

You cannot use Image Overlay with the following functions.

- Sort
- Rotate Sort
- Format Overlay

If you use the Shift function with the Additional Copy function after creating an Image Overlay copy, the composite image is moved. You cannot move the individual original images.

When using the following functions, the effects are applied to the composite image created with Image Overlay.

- Shift
- Margin Adjustment
- Border Erase
- Area Selection
- Mirror Image
- Double Copies
- Image Repeat

The maximum size for the original and the image is A1(D).

Format Overlay

The optional HDD are required to use this function.

Two images (original + format) are combined on one copy using stored image (user format) or first original.

You can store the format original and recall it for next use.

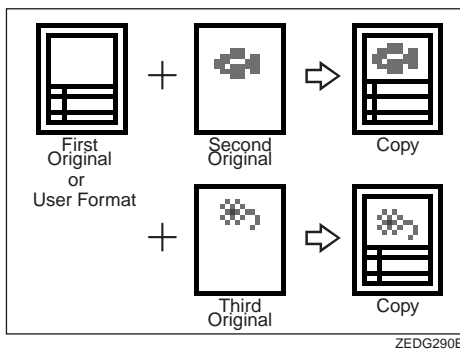

1 Press the [Edit Image] key.

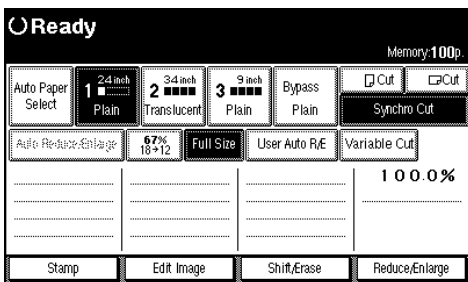

2 Press the [Format Overlay] key.

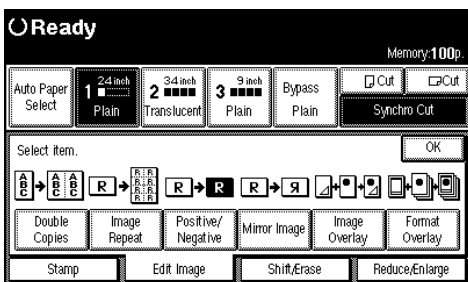

Scanning the format original (background original)

2

1 Press the [First Original] key.

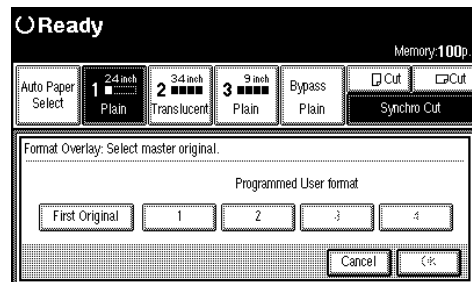

2 Press the [OK] key.

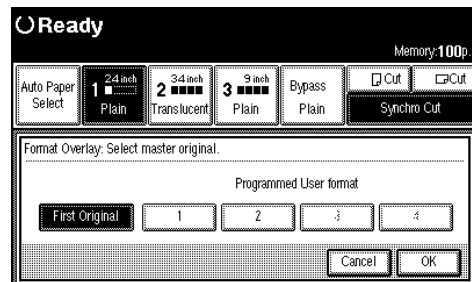

3 Make the desired settings, and then place the first original.

4 Place the second original.

The machine makes a composite copy of the first and second originals.

5 Place the third original.

The machine makes a composite copy of the first and third originals.

6 Place any other originals, as required.

Storing a format overlay beforehand

Note

- To use User Format Overlay, you need to use Program /Delete, Overlay Format. See P.84 “Program/Delete, Overlay Format”

1 Select a stored format original.

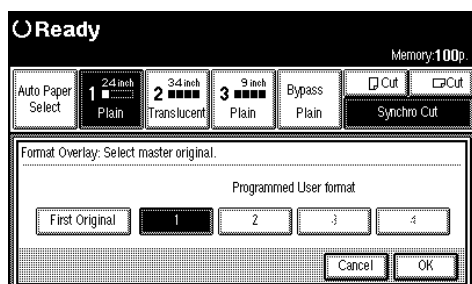

- 2 Press the [OK] key.**
- 3 Select the desired settings, and place the original to be overlaid on the format original.**

The machine makes a copy overlaying the first original on the user format original.

4 Place any other originals, as required.

The machine makes a copy overlaying the new original on the user format original.

Limitation

- When selecting the [First Original], if the sizes of the first original and the original to be overlaid on the first original are different, the image is created at the size of the overlaid original.

- When selecting the programmed user format, if the sizes of the programmed user format and the original to be overlaid on the programmed user format are different, the image is created at the size of the overlaid original.
- You cannot use Format Overlay with the following functions.
 - Image Overlay
 - Sort
 - Rotate Sort
- The maximum size for the paper size is A1 (D).

Program/Delete, Overlay Format

Preparation

The maximum size for the original size to be stored is A0 (E). You cannot store long length originals.

- 1 Make sure that the machine is ready to copy.**
- 2 Press the [User Tools/Counter] key.**
- 3 Press the [Copier Features] key.**
- 4 Press the [Adjust Image] key, and then press the [Program/Delete, Overlay Format] key.**

Storing

- 1 Select a format number (1 – 4).

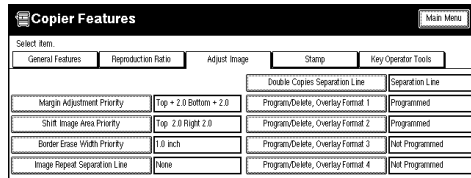

- 2 Place your originals.

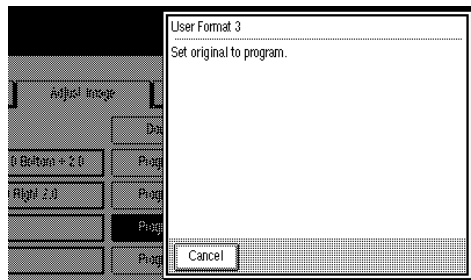

- 3 To store another original, repeat steps 1 – 2.

Overwriting a stored format

- 1 Select the format number for the format you want to overwrite.
- 2 Press the [Program] key.

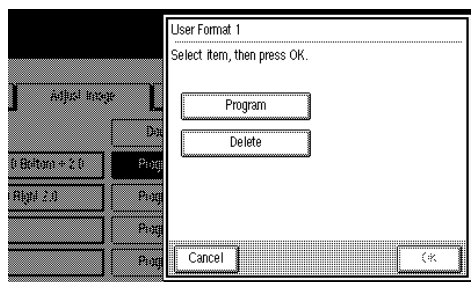

- 3 Press the [OK] key.
- 4 Press the [OK] key.

Note

- If you do not want to overwrite the existing format, press the [No] key.

Important

- You cannot restore a format that has been overwritten.

- 5 Place your originals.

Deleting

- 1 Select the format number for the format you want to delete, and then press the [Delete] key.

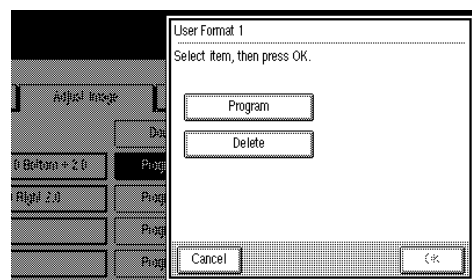

- 2 Press the [OK] key.
- 3 Press the [OK] key.

Note

- To cancel the deletion, press the [No] key.

Important

- You cannot restore a format that has been deleted.

- 5 Press the [User Tools/Counter] key.

The machine exits Program/Delete and is ready to copy.

2

Background Numbering

The optional stamp board and HDD are required to use this function.

This function produces copies which have been stamped by the numbering user stamp.

2

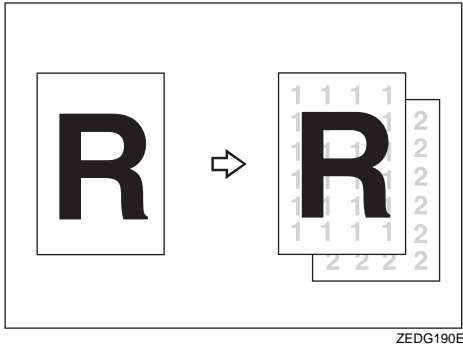

Preparation

You can set the start number from 1 to 999.

Note

- You can change the density of the background numbers. See P.137 "Background Numbering Format"
- You can change the size of the background numbers. See P.137 "Background Numbering Format"
- You can combine this function with other (up to two) print functions.

1 Press the [Stamp] key.

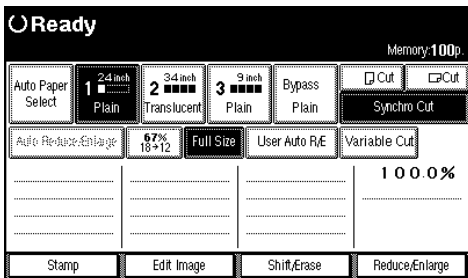

2 Press the [Background Numbering] key.

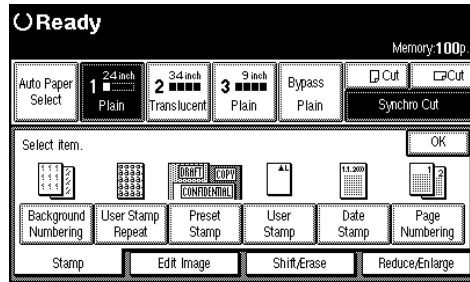

3 Enter the start number with the number keys, and then press the [OK] key.

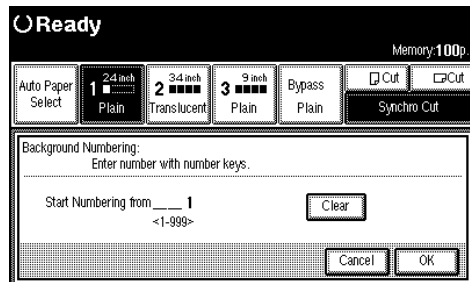

Note

- To change the value, press the [Clear/Stop] key, and then enter the new value.

4 Press the [OK] key.

User Stamp Repeat

The optional stamp board and HDD are required to use this function.

Prints a stored user stamp of letters or symbols on the whole area of the paper.

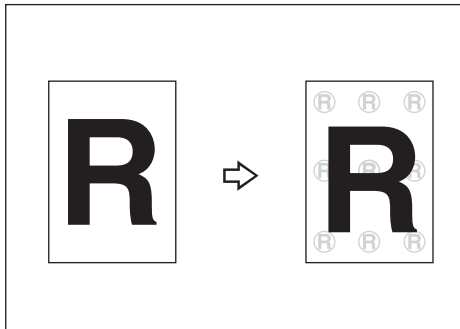

ZEDG270E

Preparation

You must store a User Stamp before using this function. See P.91 "Program/Delete, User Stamp"

You can store up to four User Stamps.

You can choose to print the User Stamp vertically or horizontally.

You can use this function with the Background Numbering and Date Stamp (up to two types) functions.

The Size, Density, Positive/Negative settings, in "User Stamp Conditions" are also applied to the User Stamp. See P.138 "User Stamp Format Priority"

Limitation

- You can use paper sizes up to A0.

Note

- When the User Stamp Repeat function is selected, it may take longer for the first copy to be printed.

Reference

For details on deleting a User Stamp, see "Program/Delete, User Stamp". See P.91 "Program/Delete, User Stamp"

1 Press the [Stamp] key.

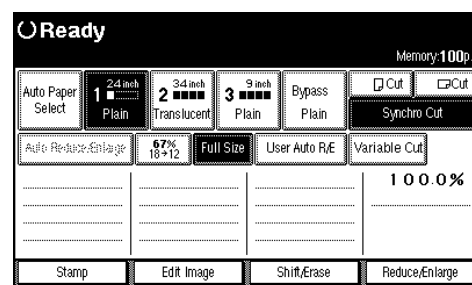

2 Press the [User Stamp Repeat] key.

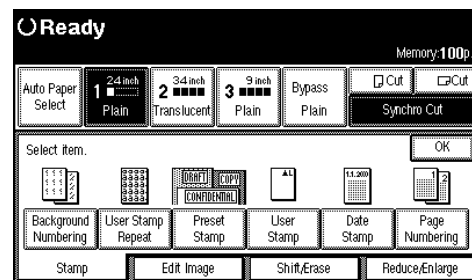

3 Select the user stamp item (stamp number).

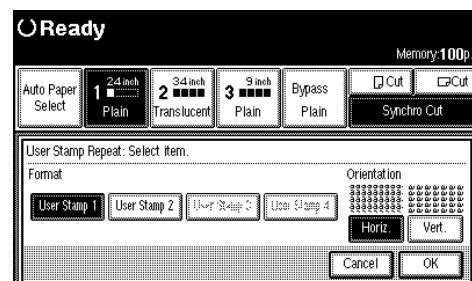

4 Select the stamp direction ([Horiz.] or [Vert.] keys.)

5 Press the [OK] key.

2

Preset Stamp

The optional stamp board and HDD are required to use this function.

Prints a user stamp that has already been stored.

2

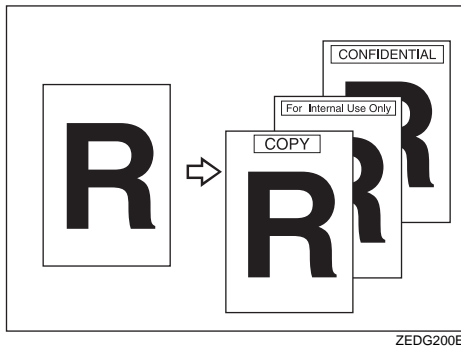

Preparation

The stamp types are as follows.

COPY	URGENT
PRIORITY	For Your Info.
PRELIMINARY	For Internal Use Only
CONFIDENTIAL	

You can change the position and direction of the stamp.

You can use this function with Background Numbering and Date Stamp.

- ❖ Place your originals, and then specify the user stamp position and direction.

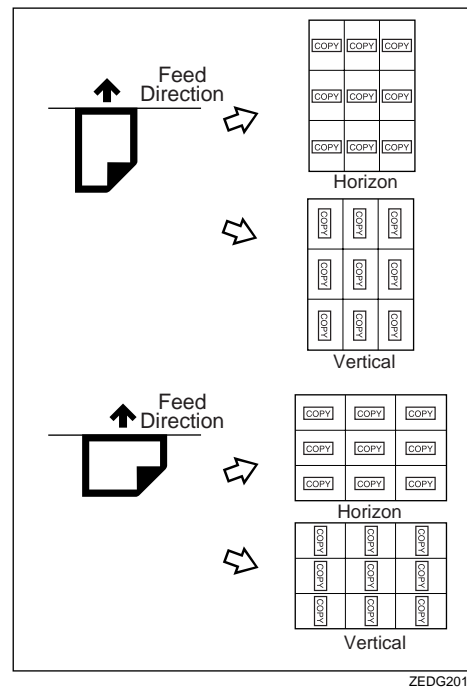

Limitation

- You cannot use the bypass tray.
- You can only use one type of stamp at a time.
- You can print on paper sizes up to A0 (E).

Note

- You can change the size, density and print position of the stamp.
- You can change the default print position for the stamp. See P.135 "Preset Stamp Format Priority"

1 Press the [Stamp] key.

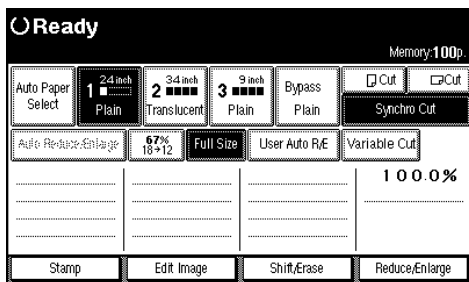

2 Press the [Preset Stamp] key.

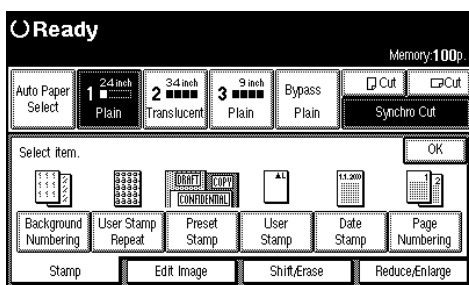

3 Select the stamp type.

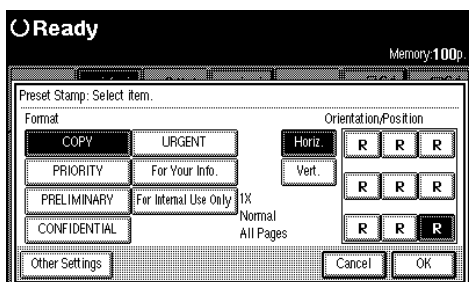

Note

- You can change the priority of the selected stamp. See P.134 "Preset Stamp Priority"

4 Select the print direction ([Horiz.] or [Vert.] keys), and print position for the stamp.

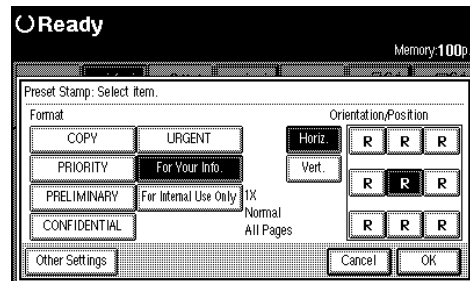

2

Changing the size and density/setting print page

1 Press the [Other Settings] key.

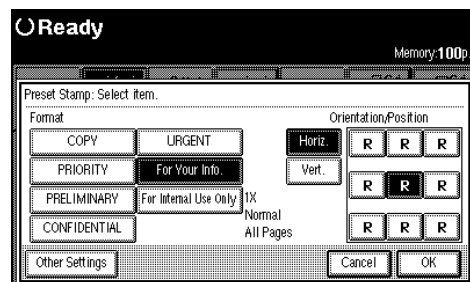

2 Sets the Size, Density and Pagination.

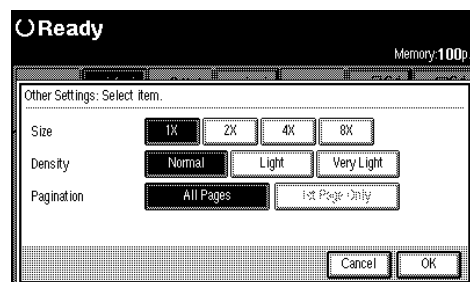

5 Press the [OK] key.

Reference

For details on how to set the originals, see "Setting Originals and Print Position/Direction". See P.90 "Place the originals and then specify the stamp position and direction."

User Stamp

The optional stamp board and HDD are required to use this function.

You can store frequently used characters or symbols, and then use them as a stamp.

2

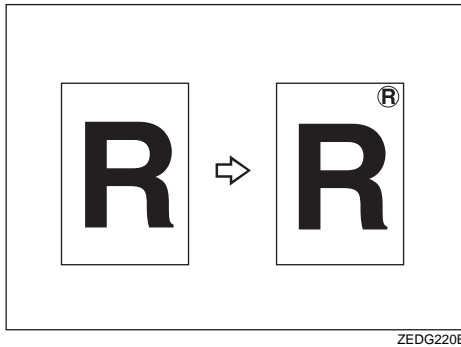

ZEDG220E

Preparation

You must store a user stamp. See P.91 "Program/Delete, User Stamp"

You can store up to four types of user stamps.

You can use a stored user stamp for User Stamp Repeat.

You can use this function with the Background Numbering and Date Stamp (up to two types) functions.

You can change the stamp position and direction.

Reference

For details on how to delete a stored user stamp, see P.91 "Program/Delete, User Stamp".

❖ Place the originals and then specify the stamp position and direction.

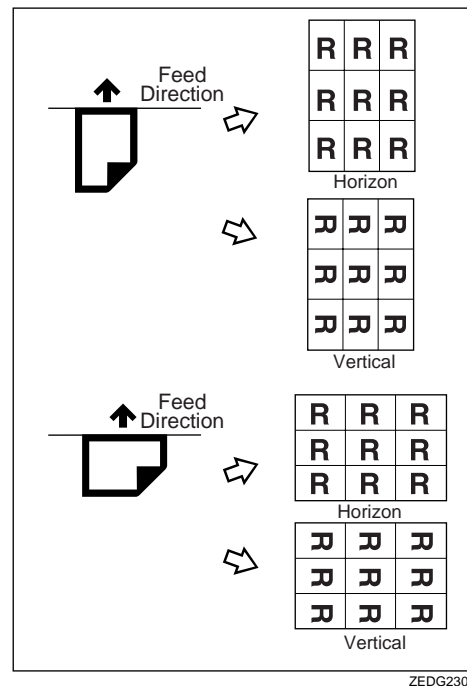

ZEDG230E

Limitation

- You cannot use the bypass tray.
- You can print on paper sizes up to A0.

Note

- You can change the default size, density and print position of the stamp. See P.138 "User Stamp Format Priority"
- When User Stamp is selected, it may take longer for the first copy to be printed.

1 Press the [Stamp] key.

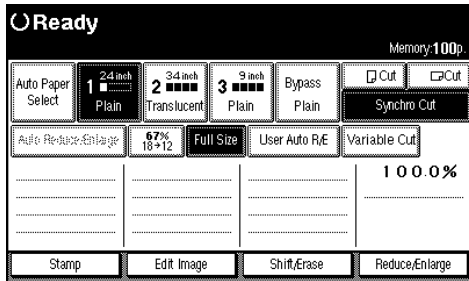

2 Press the [User Stamp] key.

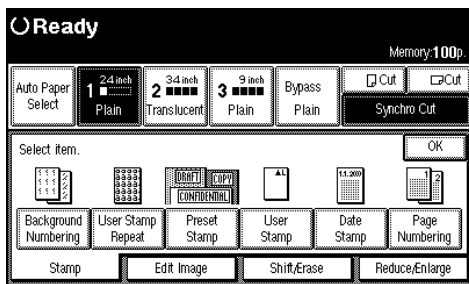

3 Select the number for the user stamp.

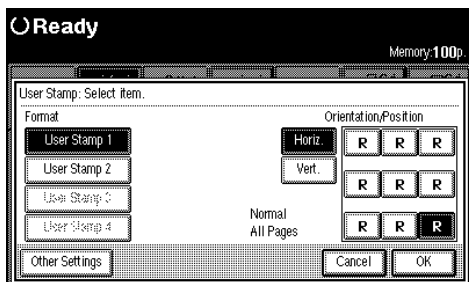

4 Select the print direction ([Horiz.] or [Vert.] keys) and print position.

Changing the density/setting print page

1 Press the [Other Settings] key.

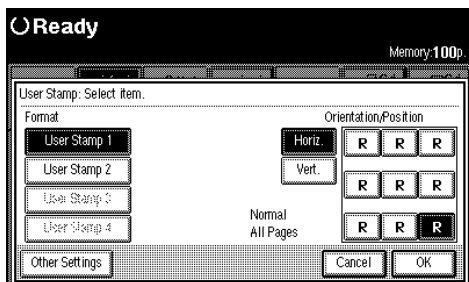

2 Set the Density and Pagination.

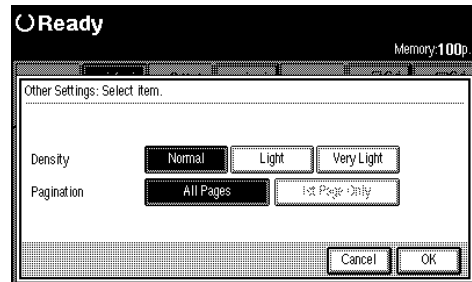

2

5 Press the [OK] key.

Reference

For details on how to set the originals, see P.31 "Setting Originals".

Program/Delete, User Stamp

Preparation

If the stamp printed on the original is bright red or red, it may not be scanned clearly. To store a stamp, use either a stamp printed with black ink, or make a copy and use the copy as the original.

1 Check that the machine is ready to copy.

2 Press the [User Tools/Counter] key.

3 Press the [Copier Features] key.

4 Press [Print Settings] key, and then press the [Next] key.

"Print Settings 2/2" is displayed.

5 Press the [Program/Delete, User Stamp] key.

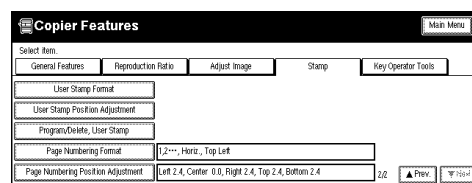

2

Storing

- 1 Select the number you want to use to store the stamp, and then press the [OK] key.

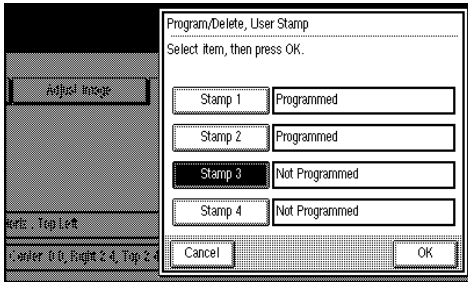

- 2 Place your originals.

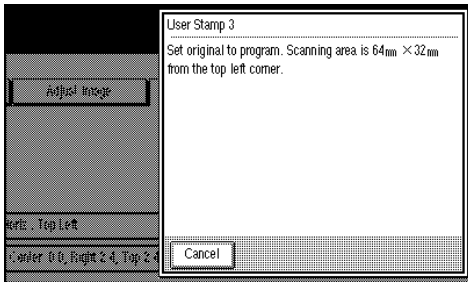

Note

- The area in the top right of the original of 64x32mm, 2.6"x1.3" is stored as a user stamp.

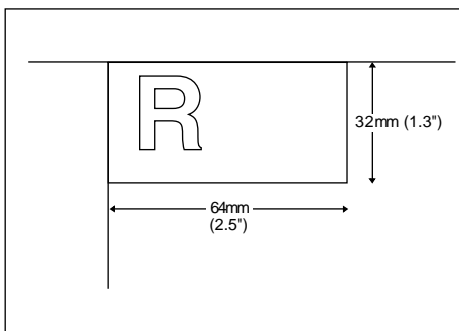

ZEDG240E

- You can specify the print conditions for stored stamps. See P.138 "User Stamp Format Priority"

Overwriting a stored user stamp

- 1 Select the number for the stamp you want to overwrite, and then press the [OK] key.

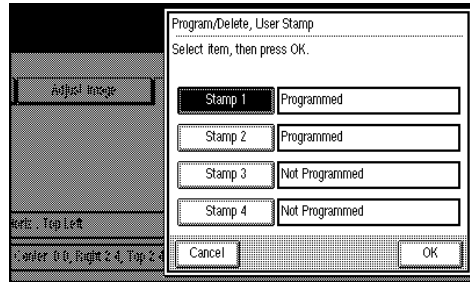

- 2 Press the [Program] key.

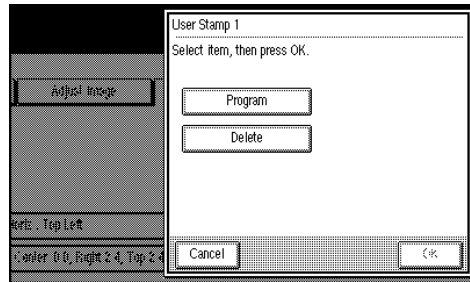

- 3 Press the [OK] key.

- 4 Press the [OK] key.

Note

- If you do not want to overwrite the existing stamp, press the [No] key.

Important

- You cannot use as original stamp before overwriting.

- 5 Place your originals.

Deleting

- ❶ Select the number of the stamp you want to delete, and then press the [OK] key.
- ❷ Press the [Delete] key.

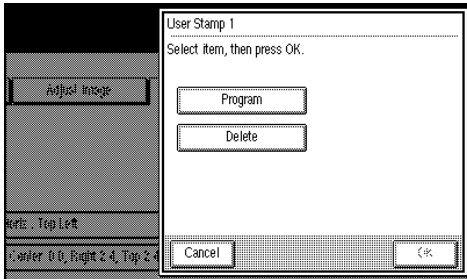

2

- ❸ Press the [OK] key.

"Are you sure you want to delete this programmed stamp?" is displayed on the screen.

- ❹ Press the [OK] key.

 **Note**

- To cancel the deletion, press the [No] key.

 **Important**

- You cannot use a user stamp which has been deleted.

- ❺ Press the [User Tools/Counter] key.

After the default settings have been changed, the machine is ready to make copies.

Date Stamp

The optional stamp board and HDD are required to use this function.

2

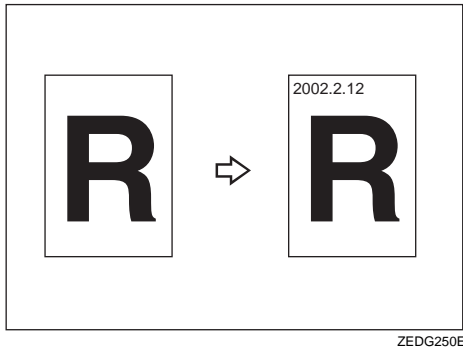

ZEDG250E

Preparation

Specify the print position (Top left/Top centre/Top right/Bottom left/Bottom centre/Bottom right) and print direction (Horizontal/Vertical).

- ❖ Place your originals, and then specify the date stamp position and direction.

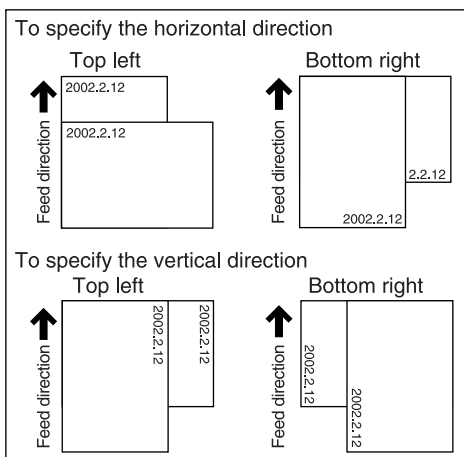

ZEDG260E

Limitation

- ❑ You cannot use the bypass tray.
- ❑ You can print on paper sizes up to A0.

Note

- ❑ You can change the date format of the date stamp. See P.136 "Date Stamp Format Priority"
- ❑ You can also set and change the other date stamp conditions. See P.136 "Date Stamp Format Priority"
- ❑ You can use the date stamp with (up to two) other user stamps.
- ❑ The date set in "Time Settings" is used for the date stamp. See the System Settings manual.

1 Press the [Stamp] key.

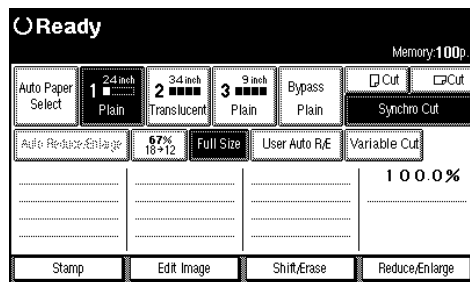

2 Press the [Date Stamp] key.

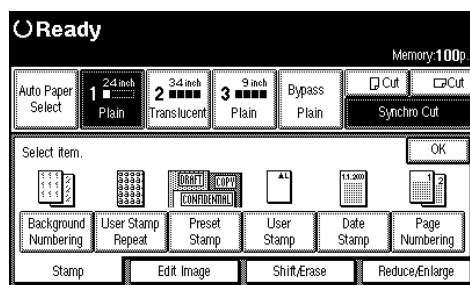

- 3** Select the date format for the date stamp.

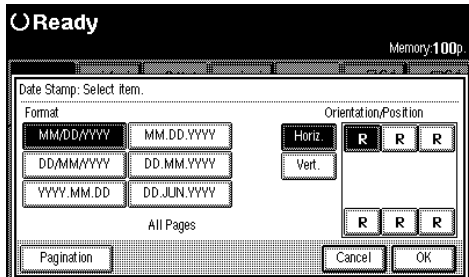

2

- 4** Select the print direction ([Horiz.] or [Vert.] keys) and the print position.

Selecting pagination

- 1** Press the [Pagination] key.

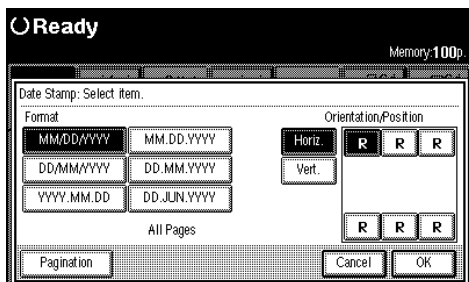

- 2** Select the [All Pages] or [First Page Only] key, and then press the [OK] key.

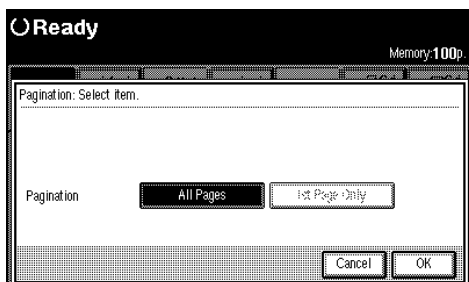

- 3** Press the [OK] key.

Page Numbering

The optional stamp board and HDD are required to use this function.

Use this function to print page numbers on your copies. There are five types of Page Numbering.

2

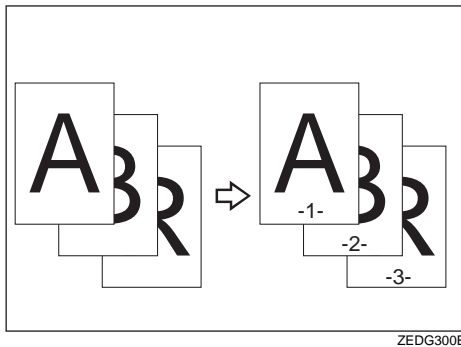

There are five types of Page Numbering.

- 1, 2,...
- -1-, -2-,...
- P1, P2,...
- P.1, P.2,...
- 1/5, 2/5,...

Limitation

- When using the function with the bypass tray selected, the print position will be based on the original size multiplied by the magnification ratio.

Note

- You can finely adjust the default setting for the page print position. See P.140 "Page Numbering Position Adjustment"
- You can change the default settings for the format, print direction, and print position. See P.139 "Page Numbering Format"

1 Press the [Stamp] key.

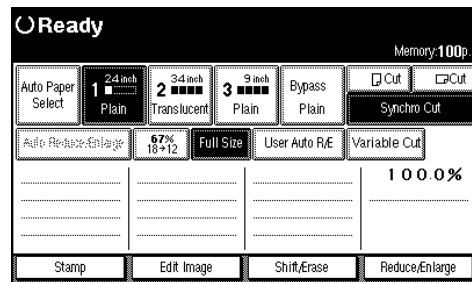

2 Press the [Page Numbering] key.

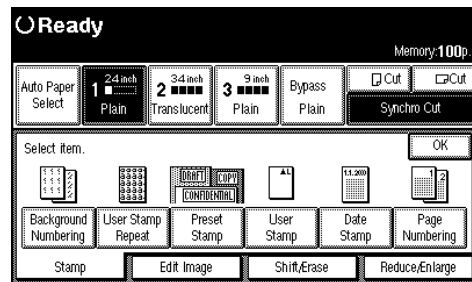

3 Select the page print format.

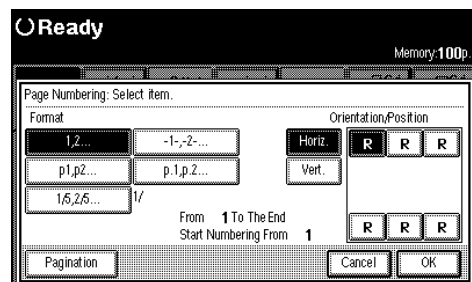

4 Select the print direction ([Horiz.] or [Vert.] keys) and print position.

Selecting first page to Print/Last Page to print and start numbering from

- ① Press the [Pagnation] key.
- ② To change the first/last page, and starting page, press the corresponding key, and then enter the value with the number keys. Then press the [#] key.

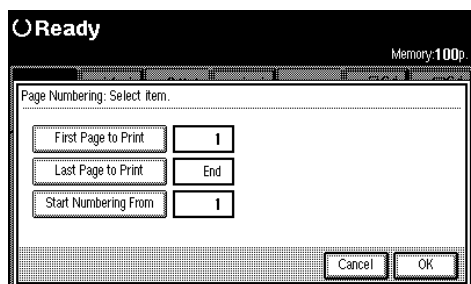

Note

- To change the value, press the [Clear] key, and then enter the new value.

- ③ Press the [OK] key.

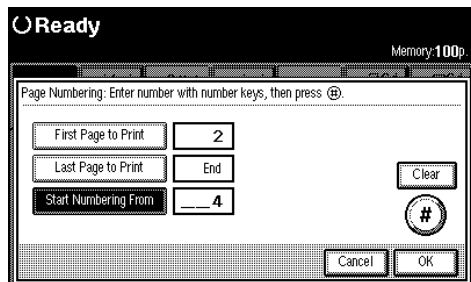

If [1/5,2/5...] are selected

If you select [1/5,2/5...] the screen for setting fractions is displayed.

- ① Enter the denominator with the number keys.

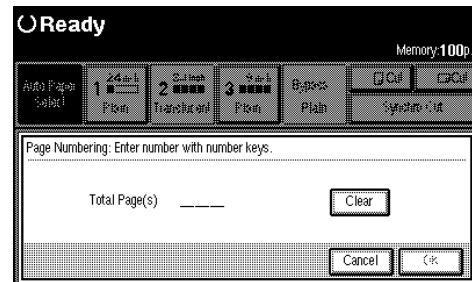

Note

- To change the value, press the [Clear] key, and then enter the new value.

- ② Press the [OK] key.

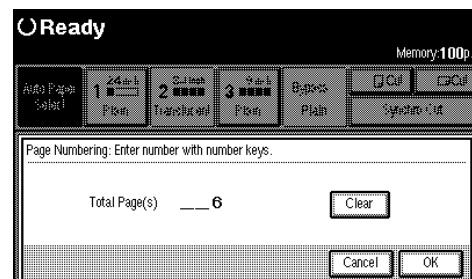

- ⑤ Press the [OK] key.

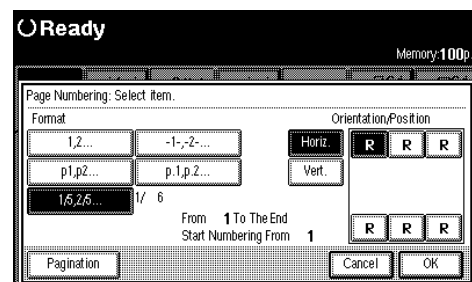











Already selected function	Required Options	Shift		Stamp				Sort	Paper Cut	Copy Mode							
		You try to select mode	Shift	W	W	W	W	W									
		Margin Adjustment	Background Numbering	User Stamp	Date Stamp	Page Numbering	User Stamp Repeat	Sort	Rotate Sort	Synchro Cut	Variable Cut	Preset Cut	Sample Copy	Partial Copy	Print Start Trigger-Press Start Key	Job Preset	Interrupt Copy
	Already selected mode																
Paper Select	Auto Paper Select	F								B	B	B					
	Manual Paper Select																
Reduce/Enlarge	Bypass Tray	F						F	F	B	B	B	F				R
	Preset Reduce/Enlarge																
	User Reproduction Ratio							F									
	Zoom							F									
	Size Magnification							F									
	Auto Reduce/Enlarge	F								B	B						
	User Auto Reduce/Enlarge	F								B	B	B					
Original Type Setting	Directional Magnification							F									
	Fine Magnification							F									
	Original Size Auto Detect							F									
	Text																
	Text/Photo																
	Photo																
	Pale																
Copy Image Density	Generation																
	Blue Erase																
Paper Type	Patched Original																
	Photo (Hard Tone)																
Edit Image	Auto Image Density																
	Manual Image Density																
Erase	Plain paper																
	Translucent paper																
	Translucent film																
	Positive/Negative																
	Mirror Image																
	Double Copies	F	F						F								
Shift	Image Repeat							F	F								
	Image Overlay							F	F								
	H Format Overlay							F	F								
	H Storing Format Overlay							F	F								
Stamp	Border Erase							F	F				F				
	Delete Inside/Outside							F	F								
Sort/Rotate Sort	Shift							F									
	Margin Adjustment							F	F	F	F	F					
	W Background Numbering																
	W Preset Stamp																
	W User Stamp			B	B		F										
	W Date Stamp					B											
	W Page Numbering				B												
W User Stamp Repeat			B	B													
Setting the Length of Copy Paper Cut	Sort							B					F	F			R
	Rotate Sort	F	F					B	B	B			F	F			R
	Synchro Cut							F	F	B	B						
Copy Mode	Variable Cut							F	B	B							
	Preset Cut	F							B	B							
	Sample Copy							F	F				B				
	Partial Copy	F						F	F				B				F
Image Overlay (before 2nd scan)	Print Start Trigger-Press Start Key							F	F						F		R
	Job Preset				F	F	F	F	F				F	F			F
	Interrupt Copy			F	F	F	F	F	F								F
	Restart																
Sort (when scanning)																	
Rotate Sort (when scanning)																	
Image Overlay (before 2nd scan)																	

❖ Symbols used in the chart

Blank	means that these modes can be used together.
F	means that these modes cannot be used together. The mode you select will be the mode you're working in.
B	means that these modes cannot be used together. The mode you select will be the mode you're working in.
S	means that these modes cannot be used together. A message is displayed telling you that the mode cannot be selected and the machine stops.
R	means you cannot set modes after the original has been scanned.
Numerical value	means the number of the modes that can used together.
1	means full size copying, B for preset ratio
2	only shown if the margin setting is a + setting. A - setting is impossible.
3	means that when additional copy is selected, you cannot set new settings means that the previous settings can be reset, changed, or deleted.
○	means that these modes cannot be used together. The mode you select will be the mode you're working in.
×	means that these modes cannot be used together. The mode you select will be the mode you're working in.
Required option	
W	stamp board and optional HDD
H	optional HDD

Chart of Scan Sizes for Each Function

The following chart shows the scan size limitations for Shift, Margin Adjustment, Edit Image, and Print functions.

Functions		Standard	Optional HDD installed
Shift		A0(E)	less than 6m (236")
Margin Adjustment		A0(E)	less than 6m
Image Overlay	Image Overlay	A1(D)	A0 (E) 
	Format Overlay	—	A0 (E) 
Erase	Delete Inside	A1 or smaller, 5 location. A0/D or smaller 1, location.	A1 or smaller, 5 location. A0/D or smaller 1, location.
	Delete Outside	A1 or smaller, 5 location. A0/D or smaller 1, location.	A1 or smaller, 5 location. A0/D or smaller 1, location.
	Border Erase	A0 (E)	less than 5.5m (216")
	with Delete Inside, Border Erase, and Image Overlay	A1 (D)	A0 (E) 
	Delete Outside and Image Overlay Combinations	A1 (D)	A0 (E) 
	with Delete Inside, Border Erase, and Format Overlay	A1 (D)	A0 (E) 
	with Delete Outside and Format Overlay	A1 (D)	A0 (E) 
Positive/Negative		A0 (E)	less than 6m (236")
Mirror Image		less than 6m (236")	less than 6m
Double Copies		Output: A0 (E)	less than 6m (236")
Image Repeat	with no other modes	A0 (E)	A0 (E) 
	with Border Erase	A0 (E)	A0 (E) 
	with Image Overlay	A1 (D)	A0 (E) 
	with Format Overlay	—	A0 (E) 
Stamp		A0	A0









3. Troubleshooting

If Your Machine Does Not Operate As You Want

Error Messages

Machine's Condition	Problem/Cause	Action
Please wait.	Displayed when the main power is turned on, when the paper type (plain paper / translucent paper (vellum) / film) is changed, the toner is replaced, or other situations when the machine is getting ready.	Wait for the machine to warm-up. Note <input type="checkbox"/> When the message "Ready to Copy" is displayed, you can make the settings for your copies and scan your originals. After the originals have been scanned, the machine will automatically start copying after it has warmed-up. See P.130 "Feed Start Trigger"
Cannot detect original size.	Improper original is set.	Select paper roll manually, not in Auto Paper Select.
Change the orientation of the originals and try scanning it again.	In User Auto Reduce/Enlarge, the original is set to <input type="checkbox"/>	For User Auto Reduce/Enlarge, set the original to <input type="checkbox"/>
	In User Auto Reduce/Enlarge the original is set to <input type="checkbox"/>	For User Auto Reduce/Enlarge set the original to <input type="checkbox"/>
Memory is full.	The machine's memory is full because the number of originals scanned or for performing a function. The number of originals that can be stored in memory depends on the size of the originals and the function settings.	<ul style="list-style-type: none"> When the Sort function is selected, press the [Finish] key to copy the scanned originals, and then copy the remaining originals. When the Job Preset function is selected, check the number of preset jobs, and then try scanning the originals again.
	When using the Repeat Copy with the scanning A0(E) size original.	Clear the Repeat Copy function.

3

Machine's Condition	Problem/Cause	Action
Original orientation: 	The machine is set for  originals.	Change the orientation (direction) of the original.
Original orientation: 	The machine is set for  originals.	You can specify whether  or  originals have priority. See "Basic Setting 1/3" in the System Settings manual.
Check paper size.	The paper size is different to the size of the original.	<ul style="list-style-type: none"> Set the suitable paper, or change paper roll selecting. Reset the function settings, and then try again.
Rotate Sort mode is not available with the current settings.	The scanned original is too big to rotate.	You cannot use rotate sort with A0 (E) originals.
	A paper size suitable for rotate sort has not been selected.	Set paper with the following dimensions; A2 594 × 420mm, A3 420 × 297mm, A4 297 × 210mm. ❖ Inch version (Engineering) <ul style="list-style-type: none"> 11" × 8¹/₂" 17" × 11" 22" × 17" ❖ Inch version (Architecture) <ul style="list-style-type: none"> 12" × 9" 18" × 12" 24" × 18"
Maximum copy quantity:	The number of copies exceeds the maximum copy quantity.	You can change the maximum copy quantity that you can make at a time. See P.128 "Maximum Copy Quantity"
Misfed original is located in this area. Open the indicated cover and remove misfed original.	The original has jammed (original misfeed). When you press the [Scanner Stop] key while original is being fed through the machine.	Follow the on-screen instructions to remove the jammed original. See P.117 "  Clearing Misfeeds"
Misfed paper is located in these areas. Open the indicated areas and remove misfed paper.	The copy paper has jammed.	Follow the on-screen instructions to remove the jammed paper. See P.117 "  Clearing Misfeeds"

Machine's Condition	Problem/Cause	Action
Add Toner.	The machine has run out of toner.	Open the toner supply cover and change the toner cartridge. See P.115 " Adding Toner "
Close the indicated covers.	The indicated cover(s) is open.	Follow the on-screen instructions to close the cover.
Used toner bottle full.	Used toner bottle full.	Call your service representative.

Screen

3

Problem	Cause	Action
The screen is off.	The screen contrast knob is turned to the dark position.	Turn the screen contrast knob until you can see the screen.
	The machine is in Energy Saver mode.	Press the [Clear Modes/Energy Saver] key to cancel Energy Saver mode.
	The operation switch is turned off. (The Auto Off function has turned the machine off.)	Turn on the operation switch. You can change the Auto Off time. See "Auto Off Timer" of the "System Settings" manual.
Cannot select the functions on the screen.	Selected functions cannot be used together.	See P.98 " Combination Chart ".
	Function requires the stamp board or other option.	Some functions require an option.
The power does not come on.	The main power switch is turned off.	Turn on the Main power switch. See P.11 " Turning On the Main Power "

If You Cannot Make Clear Copies

3

Problem	Cause	Action
Black or white streaks appear on the copy.	The image density is too dark.	Adjust the image density. See P.41 " <i>Adjusting Copy Image Density</i> "
	The exposure glass or feed roller is dirty.	Clean the exposure glass or feed roller. See P.148 " <i>Maintaining Your Machine</i> "
	The original is dusty.	Clean the original and try copying again. Be particularly careful when using the following types of original. <ul style="list-style-type: none"> • Hand drawn or other originals drawn with a pencil or pen, such as from a plotter. • Film, translucent paper (vellum) or other originals that easily attract static electricity. • Very long originals.
A shadow of the reverse side of an original image is also copied.	The image density is too dark.	Adjust the image density setting. See P.41 " <i>Adjusting Copy Image Density</i> "
The background is dirty.	The image density is too dark.	Adjust the image density setting. See P.41 " <i>Adjusting Copy Image Density</i> "
The edges of pasted sections are shown.	The image density is too dark.	Adjust the image density setting. See P.41 " <i>Adjusting Copy Image Density</i> " Change the direction of the original. Put mending tape on the pasted part.
The same copy area is dirty whenever making copies.	The exposure glass or feed roller is dirty.	Clean the exposure glass or feed roller. See P.148 " <i>Maintaining Your Machine</i> "

Problem	Cause	Action
Copies are too light.	The image density is too light.	Adjust the image density setting. See P.41 "Adjusting Copy Image Density"
	Damp or rough grain paper is used.	For good copy quality, use the recommended paper. Note <input type="checkbox"/> If you use coating paper (such as thermal fax paper, art paper, carbon paper), dry paper, or rough grain paper, the copy image might be too light.
The toner fusing is poor.	The toner fusing temperature is too low.	Adjust the fusing setting for the paper. See "Fusing Adjustment: Paper Tray" in the System Settings manual.
	The copy paper is too thick.	
A moire pattern is produced on copies.	Your original has dot pattern image or many lines.	Change the direction of the original. This may prevent the moire pattern. Using [Photo] or [Photo(Hard Tone)] .
The image density is uneven.	The original has areas of solid color, or the Positive/Negative function is selected for Repeat Copy.	When using Repeat Copy with originals that have areas of solid color, set the number of originals as follows: A0 – A2 (E – C): 1 sheet, A3 (B) or smaller: 3 sheets
	Halftone originals can cause this problem.	Try using [Text/Photo] or [Photo] .
Images are blurred when using translucent paper (vellum).	Translucent paper (vellum) is being used with Repeat Copy.	Adjust the fuser setting to match the paper type. See "Fusing Adjustment: Paper Tray" in the System Settings manual.
Wrinkles appear when using translucent paper (vellum).	The fusing temperature is too low.	Adjust the fuser setting to match the paper type. See "Fusing Adjustment: Paper Tray" in the System Settings manual.
	The paper type has just been changed from plain paper to translucent paper (vellum).	Wait about one minute.

Problem	Cause	Action
The background for translucent paper (vellum) is dirty.	More than 50 copies are being made of originals longer than 1189mm (46.9") with solid block of color (2mm × 900mm (0.08" × 35.4") or larger.)	Adjust the fuser setting to match the paper type. See "Fusing Adjustment: Paper Tray" in the System Settings manual.
Streaks, scratches, or wrinkles appear in areas of solid black color.	The paper has been changed from plain paper to translucent paper (vellum), or from translucent paper (vellum) to plain paper.	After switching from plain paper → to translucent paper (vellum) wait one minute. After switching from translucent paper (vellum) → to plain paper wait two minutes before making copies.
Shadows appear on the copies.	The original is a two sided original, or image density setting is too dark.	Adjust the image density setting. See P.41 "Adjusting Copy Image Density"
The copies are blurred.	Continuous copies have been made on small sized paper.	Wait about two minutes, and then try copying again.

If You Cannot Make Copies As You Want

Problem	Cause	Action
Misfeeds occur frequently.	There are folds or wrinkles in the paper.	Remove the folds or wrinkles from the roll paper.
	Jammed paper or torn paper is inside the machine.	Remove the paper, as appropriate. See P.117 " <i>Clearing Misfeeds</i> "
	The paper is curled.	Smooth out the curl and try again.
Images are cropped when using the Border Erase function.	The Border Erase setting is too big. The margin of the original is small.	Reduce the size of the Border Erase setting. See P.72 " <i>Border Erase</i> "
Parts of the image are not copied.	The original is not placed correctly.	Placing original correctly. See P.31 " <i>Setting Originals</i> "
	An improper paper roll is selected.	Select the proper paper roll. See P.16 " <i>Copy Paper</i> "
	Shift/Erase or Margin Adjustment mode is selected.	Cancel Shift/Erase or Margin Adjustment mode. See P.68 " <i>Margin Adjustment</i> ", P.70 " <i>Shift</i> "
Copies are blank.	The original is not set correctly.	Placing the original with the surface to copied on to face up.
The copy paper shifts sideways.	The paper roll is not set correctly.	Set the paper roll correctly, making sure that it is straight and not loose. See P.113 " <i>Loading Roll Paper</i> "
	The original does not match size in the original table setting.	Adjust the original guides to the specified size, and then insert the original along the guides. See P.31 " <i>Setting Originals</i> "
	The paper is not set correctly in the bypass tray.	Make sure that the paper matches the size for the bypass tray guides. See P.46 " <i>Copying from the Bypass Tray</i> "
The copy has shifted in the direction of the original feed (or opposite) direction.	Shift/Erase or Margin Adjustment mode is selected.	Cancel Shift/Erase or Margin Adjustment mode. See P.68 " <i>Margin Adjustment</i> ", P.70 " <i>Shift</i> "
The copy is shorter than the selected size. Or the copy is cut off before the end.		

Problem	Cause	Action
Wrinkles appear in the copy.	The paper is damp.	Replace the paper with new paper. Cut the paper to 1000mm (40") just before copying.
	The paper is damp. See P.12 " <i>Anti-humidity Heater Switch</i> "	Turn on the anti-humidity heater. See P.12 " <i>Anti-humidity Heater Switch</i> "
The copies are slanted.	The original is not straight.	Insert the original along the original guides, so that it is straight.
The original and the copy size does not match.	The paper may have stretched because it is damp.	Adjust the Fine Magnification setting for the Additional Copy function. See P.61 " <i>Fine Magnification</i> " Adjust the Fine Magnification setting. See P.61 " <i>Fine Magnification</i> "
You cannot combine several functions.	Selected functions cannot be used together.	See P.98 " <i>Combination Chart</i> ".

Changing The Roll Paper Size

Change the size guides on the left and right of the roll paper holder when you load different sized paper rolls.

Important

- Always follow the instructions below when adjusting the roll paper holder. Do not force the roll paper holder by pulling or sliding it strongly. This could damage the holder.

Removing the Roll Paper Holder

3

1. Push the paper holder inwards, and then pull it upwards to remove it.

<Note>

- The paper holder is attached with magnets and a hook.
- The paper holder is on the right in this illustration.

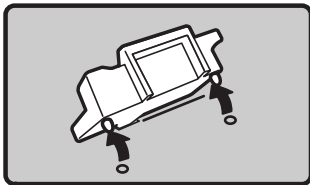

ZEDX200E

Setting the Roll Paper Holder

3

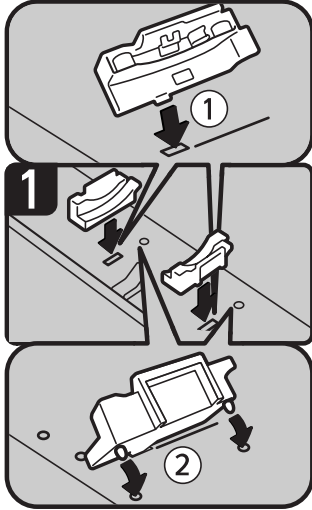

1. Insert the hook on the paper holder into the hole (①).

2. Hook on the outside and insert the hook into the hole (②).
 <Note>
 • Make sure the hook are firmly in the hole.



3. Check the paper size in the windows on the inside of the paper holder.
 <Note>
 • Set the same setting for both left and right.

• Metric version											
914	880	841	800	728	660	594	515	420	364	297	210
• Inch version											
36	34	30	24	22	18	17	12	11	9	8 1/4	

ZEDX190E

Reference

Refer to the procedure for loading paper. See P.113 “ Loading Roll Paper”.

Loading Roll Paper

⚠ CAUTION:

- *Be careful when replacing the roll paper or removing misfed paper by following the operating instructions properly. Otherwise, an injury may result from the paper cutter inside.*

⚠ Important

- When removing paper rolls, lift the roll holders on either side of paper roll before removing it. Do not lift one side only. This could damage the machine.

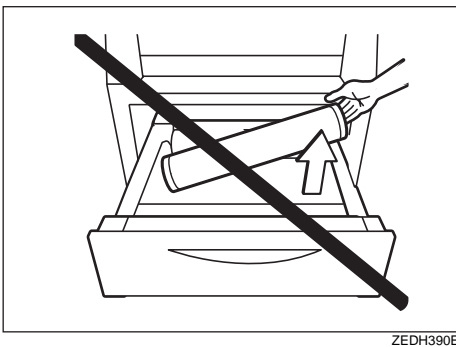

🔍 Reference

For details on the paper sizes and types that can be loaded, see ⇒ P.16 “Copy Paper”.

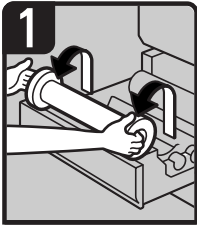

1. Hold both sides of the empty paper roll and remove it from the unit.

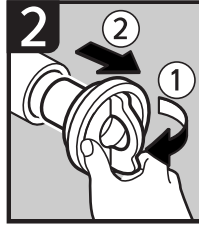

2. Raise the lever on the paper holder (①).
3. Remove the empty paper roll core from the paper holder (②).

<Note>
• Hold both sides when removing it.

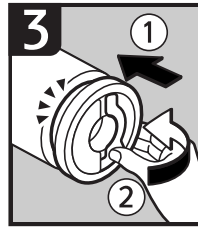

4. Set the paper holder in the new paper roll (①).

<Note>
• Insert the paper holder firmly, until it stops.
5. Lower the lever.
<Note>
• Hold both sides.

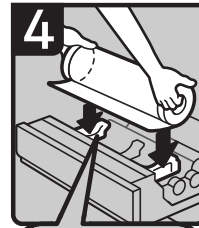

6. Hold both sides of the paper roll and set it securely in the paper holder.

<Note>
• The edge of the paper roll should be on the bottom.

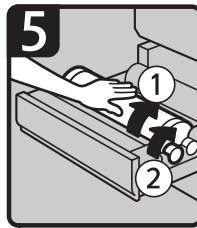

7. Rotate the paper roll slowly until the paper edge is almost fed into the rubber part of the roller (①).

<Note>
• Make sure the paper is not loose.

• Make sure the paper is straight.
8. While feeding the edge of the paper roll into the rubber part of the roller, turn the paper knob clockwise (②).

<Note>
• Watch carefully to make sure that the edge of the paper is inserted between the feeder and the roller.

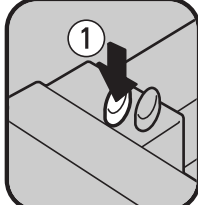

9. Press the auto feed button until the edge of the paper emerges from the cutter section (①).

<Note>
• The paper will be cut automatically when you release the feed button.
• Be careful not to get your fingers or cloths trapped in the roller.



10. Remove the cut piece of paper (②).
11. Close the paper tray.

Adding Toner

WARNING:

- *Do not incinerate used toner or toner containers. Toner dust might ignite when exposed to an open flame. Dispose of used toner containers in accordance with local regulations for plastics.*

CAUTION:

- *Keep toner (used or unused) and toner containers out of reach of children.*

CAUTION:

- *Our products are engineered to meet high standards of quality and functionality, and we recommend that you only use the expendable supplies available at an authorized dealer.*

3

Important

- If you use toner other than the recommended type, a problem might occur.
- Replace the toner while the machine is turned on. If you turn the machine off, your settings will be lost and you will not be able to resume copying.
- Always replace toner when the message is displayed.

Note

- When the indicators blink, replace the toner as soon as possible.
- If toner runs out, the message “ Out of toner.” is displayed and you cannot make copies.
- The machine will be ready to make copies again, about two minutes after the toner is replaced.

Reference

For details on how to store toner, see P.20 “Storage”.

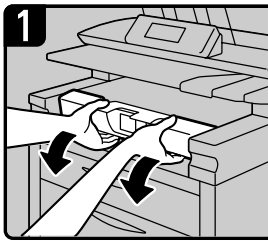

1. Open the toner supply cover.

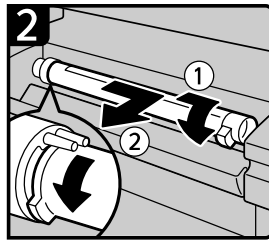

2. While sliding the toner cartridge to the right, roll it towards you (①).
3. Pull the toner cartridge towards you, and out of the machine (②).

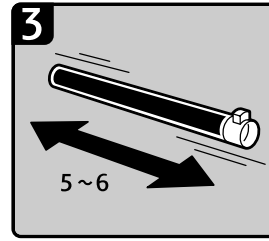

4. Remove the new toner cartridge and gently shake it five or six times.

3

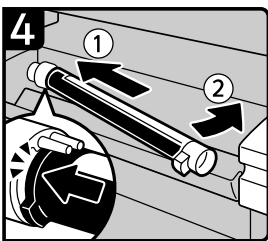

5. Insert the ends of the toner cartridge into the toner holder on the left (①).
6. Insert the toner cartridge into the right, as indicated by the arrow (②).

<Note>

- Remove the tape from the cartridge without rotating the cartridge as follows.

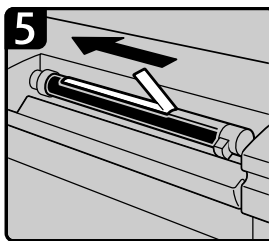

7. Slowly remove the tape from the toner cartridge.

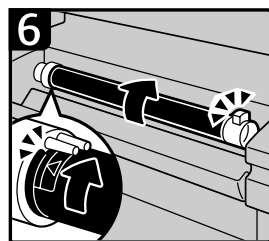

8. Rotate the toner cartridge so the arrows are at the top and secure it firmly in place.
9. Close the toner supply cover.

ZEDX120E

Clearing Misfeeds

Original Misfeeds

CAUTION:

- The fusing section of this equipment might be very hot. You should be very careful that you don't touch this section when removing the misfed paper.

Important

- If the originals are fed at a slant or become jammed, press the **[Scanner Stop]** key.
- Do not turn off the operation switch when removing jammed originals. If you turn the power off, your settings will be lost.
- Completely remove the jammed original, taking care not to tear it. If scraps of paper are left in the machine, the originals will jam again or the machine may be damaged.
- If the original misfeeds again, immediately call your service representative.

Reference

For details of the paper sizes and types that can be loaded, see P.16 "Recommended Size and Type".

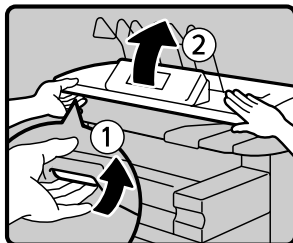
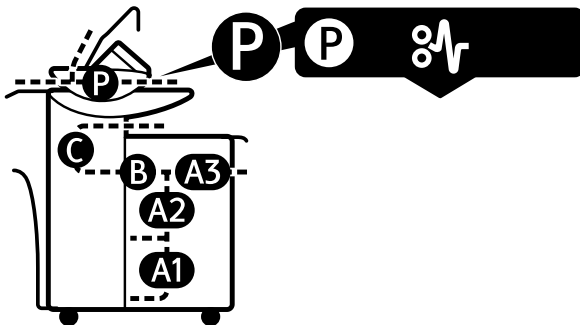

1. Lift the original cover release lever (①), and lift open the original cover (②).

<Note>

• Always hold the original cover on both sides when opening it.

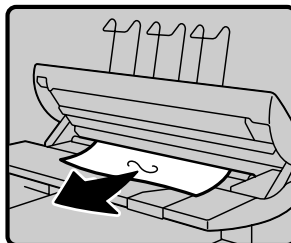

2. Remove the jammed original.

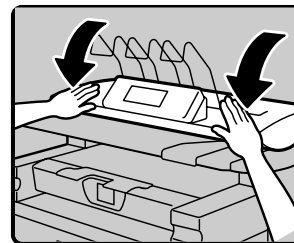

3. Gently close the original cover with both hands.

ZEDX130E

Paper Misfeeds

⚠ CAUTION:

- *The fusing section of this equipment might be very hot. You should be very careful that you don't touch this section when removing the misfed paper.*

⚠ CAUTION:

- *Be careful when replacing the roll paper or removing misfed paper by following the operating instructions properly. Otherwise, an injury may result from the paper cutter inside.*

3

⚠ Important

- ⚠ Do not open the covers, paper path section or paper roll tray immediately after the paper misfeed display blinks or comes on. Wait 10 seconds before opening them. If you open them immediately, it will be difficult to remove paper trapped in the fusing unit.
- Completely remove the jammed paper, taking care not to tear it. If scraps of paper are left in the machine, the originals will jam again or the machine may be damaged.
- If the paper misfeeds again, immediately call your service representative.

📝 Note

- Paper jam locations may be displayed in more than one place. In these cases, check all the locations indicated.
- Instructions for clearing paper jams in the copy output area and paper roll tray are contained in the stickers on the machine.

Paper roll tray (A1,A2)

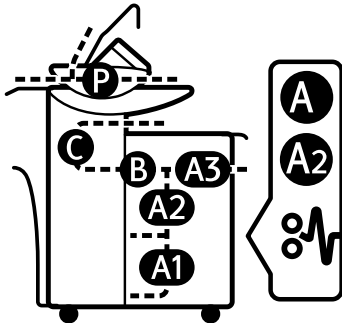

3

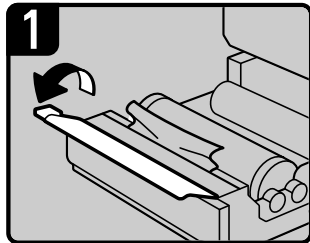

1. Open the cutter blade cover.
 <Note>
 ·Be careful not to touch the cutter blade with your fingers.

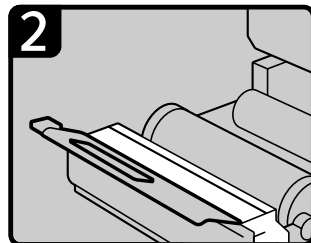

2. The next steps differ depending on whether you can see the edge of the paper or not.

·When you can see the edge of the paper.

3 ~ 5

·When you cannot see the edge of the paper.

6 ~ 9

ZEDX140E

When you can see the edge of the paper

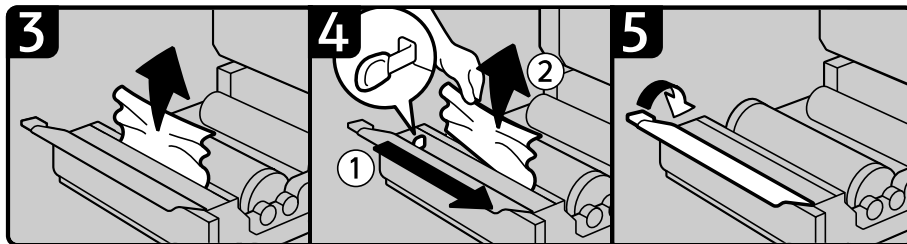

1. Slowly pull up the edge of the jammed paper.
2. Slide the cutter knob (①) to cut the edge of roll paper
3. Remove the jammed paper.
 <Note>
 ·Return the cutter knob to either the right or left side of the cutter area.
4. Close the cutter blade cover.
 <Note>
 ·Be careful not to touch the cutter blade with your fingers.

ZEDX210E

When you cannot see the edge of the paper

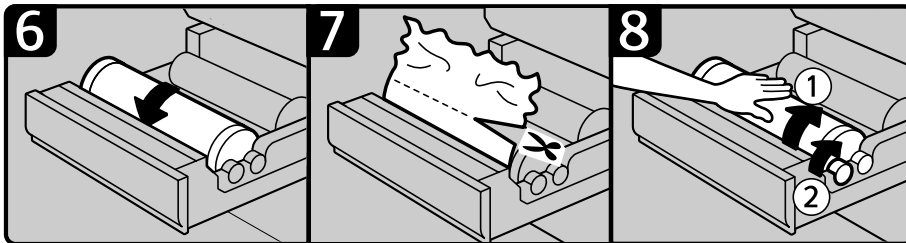

3

1. Rotate the paper roll in the direction of the arrow until you can see the edge of the paper.
2. Cut the edge of the paper with the cutter or scissors.
3. Slowly rotate the paper roll until the edge of the paper is fed into the rubber part of the roller (①).

<Note>
 • Making sure the paper is not loose, insert it straight into the roller.

4. While feeding the edge of the paper roll into the rubber part of the roller, turn the paper knob clockwise (②).

<Note>
 • Watch carefully to make sure that the edge of the paper is inserted between the feeder and the roller.

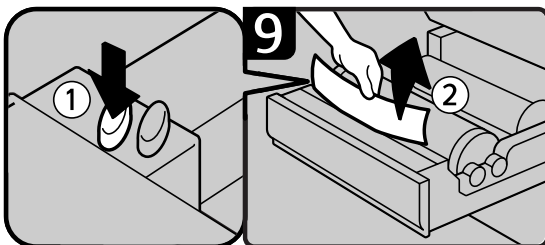

5. Press the auto feed button until the edge of the paper emerges from the cutter section (①).
 <Note>
 • The paper will be cut automatically when you release the feed button.
 • Be careful not to get your fingers or cloths trapped in the roller.
6. Remove the cut piece of paper (②).
7. Close the paper tray.

ZEDX220E

Bypass tray (A3,B)

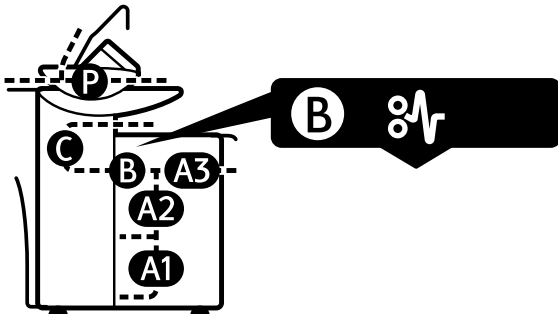

3

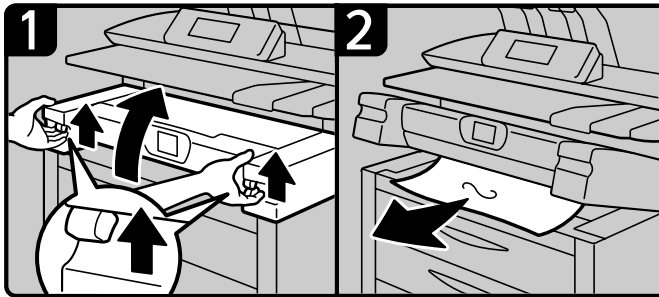

1. Lift the lever and lift out the imaging unit.
 <Note>
 • Always hold the unit on both sides when opening it.

2. Remove the jammed paper.
3. Close the imaging unit.
 <Note>
 • Always use both hands when closing the imaging unit.

ZEDX150E

Copy output (rear) (C)

Even if C is displayed, check the front area first and clear any paper jams there. If you still cannot clear the paper jam, use the following procedure.

Important

- When clearing the paper, be careful of the auxiliary guide and other protrusions.

3

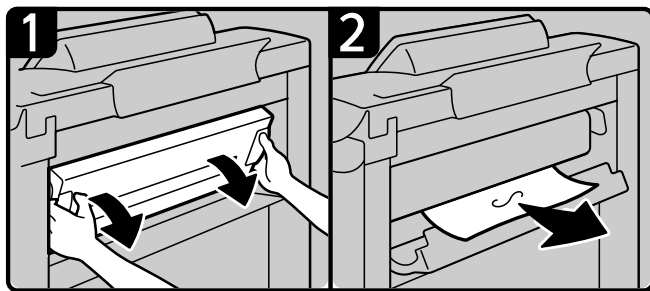
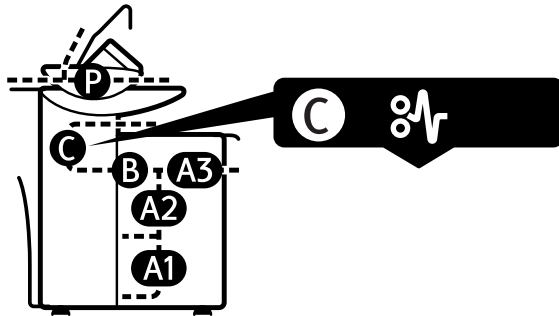

1. Open the fusing unit cover at the rear with both hands.
 <Note>
 • The fusing unit is hot. Be careful not to touch it.
2. Remove the jammed paper and close the fusing unit cover.

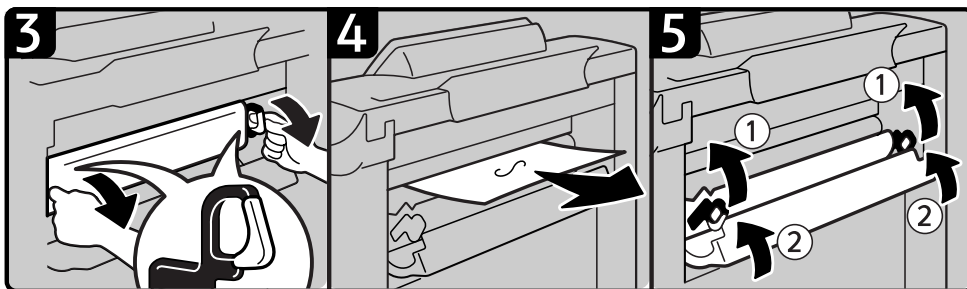

3. Hold the knobs on either side of the fusing unit and tilt the top of the fusing unit forwards.
 <Note>
 • The fusing unit is hot. Be careful not to touch it.
 • Do not place anything on the fusing unit.
4. Remove the jammed paper.
5. Close the fusing unit (①).
 6. Close the fusing unit cover (②).
 <Note>
 • Push both sides of the fusing unit and push it firmly into place until both sides lock into position.

ZEDX160E

CAUTION:

- The fusing section of this equipment might be very hot. You should be very careful that you don't touch this section when removing the misfed paper.

4. User Tools (Copier Features)

Accessing The User Tools (Copier Features)

This section is for the key operation in charge of this machine. You can change or set the machine's default settings.

Preparation

Any changes you make with the user tools remain in effect even if the main power switch or operation switch is turned off, or the **[Clear Modes/Energy Saver]** key is pressed.

Reference

For details about the System settings, see the System Settings manual.

- 1** Press the **[User Tools/Counter]** key.
The User Tools menu is displayed.

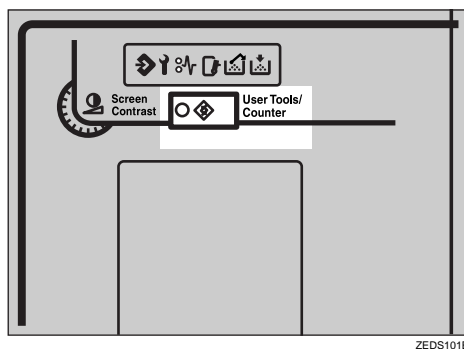

- 2** Press the **[Copier Features]** key.

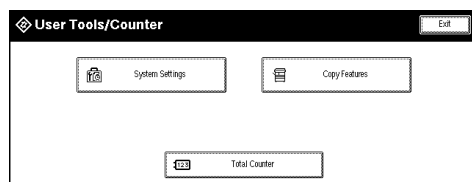

- 3** Select the desired User Tools menu.

The relevant settings screen is displayed for the item selected.

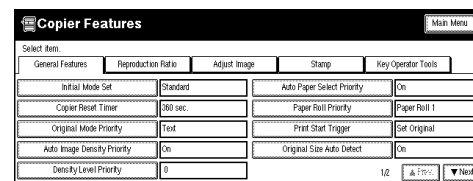

Copier Features				Main Menu
Select Item	Reproduction Ratio	Adjust Image	Stamp	Key Operator Tools
Initial Mode Set	Standard		Auto Paper Select Priority	On
Copier Reset Timer	50 sec.		Paper Roll Priority	Paper Roll I
Original Mode Priority	Text		Print Start Trigger	Set Original
Auto Image Density Priority	On		Original Size Auto Detect	On
Density Level Priority	0			1/2

Reference

⇒ P.125 "User Tools Menu (Copier Features)"

- 4** Change the settings as described in the on-screen instructions, and then press the **[OK]** key.

Note

- Use the **[.]** key to enter a decimal point.

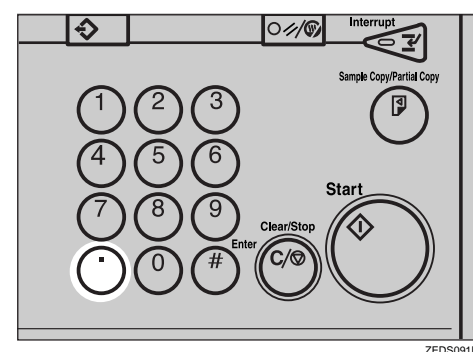

- If you press the **[Cancel]** key, the changes to the settings are cancelled and the previous screen is displayed.

 **Reference**

For details about how to set or change settings, see the System Settings manual. See P.126 “Settings You Can Change with the User Tools”

Exiting from User Tools

- 1** Press the **[User Tools/Counter]** key.
The machine exits User Tools mode and is ready for copying.

 **Note**

- You can exit from the User Tools by pressing the **[Exit]** or the **[Clear Modes/Energy Saver]** key.

4

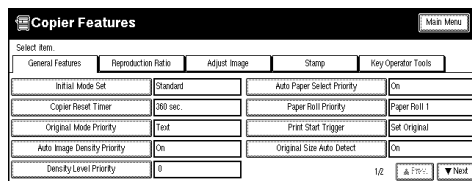

User Tools Menu (Copier Features)

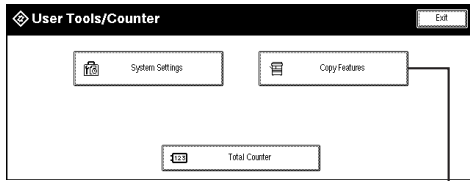

Adjust Image

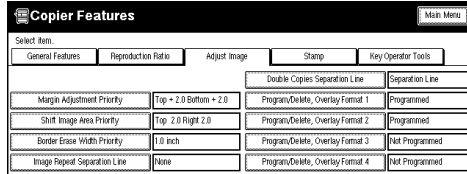

General Features 1/2

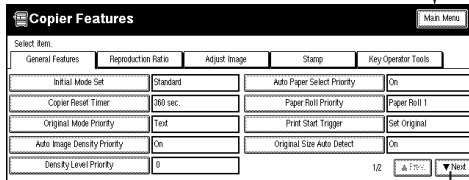

Stamp 1/2

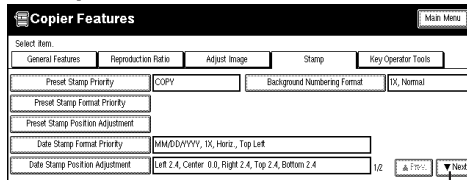

General Features 2/2

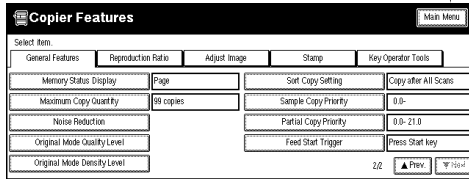

Stamp 2/2

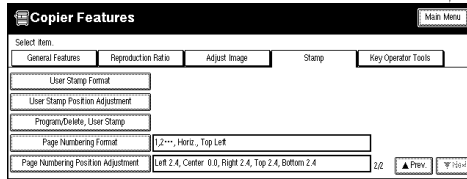

Reproduction Ratio

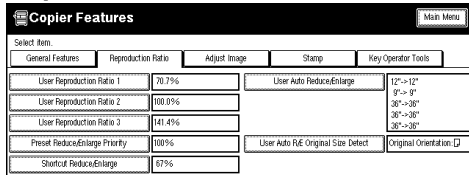

Key Operator Tools

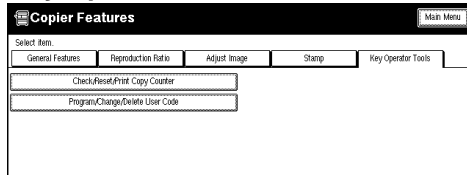

4

ZEDX101E

Settings You Can Change with the User Tools

For details about how to display the settings, see P.123 “Accessing The User Tools (Copier Features)”

General Features 1/2

❖ Initial Mode Set

Specifies the settings to appear in the Copy Initial Display screen after the machine is turned on, after Auto Reset, or after the **[Clear Modes/Energy Saver]** key has been pressed. Or whether to use the settings stored in Program No. 20.

- Standard
- Program No.20

Note

- Default: *Standard*

❖ Copier Reset Timer

Specifies the time period for Auto Reset. See P.30 “Auto Reset”

Note

- Default: *60 sec.*
- The time can be set to 0, and from 10 to 999 seconds.
- If you select 0 sec., the setting is set to No Auto Reset.

❖ Original Mode Priority

Specifies the default original type to be used after the machine is turned on, after Auto Reset, or after the **[Clear Modes/Energy Saver]** key has been pressed. See P.40 “Selecting Original Type Setting”

- Text
- Text/Photo
- Photo
- Pale
- Generation
- Blue Line
- Petched Original
- Photo (Hand Toner)

Note

- Default: *Text*

❖ Auto Image Density Priority

Specifies whether Auto Image Density should be used after the machine is turned on, after Auto Reset, or after the **【Clear Modes/Energy Saver】** key has been pressed, or not. See P.41 “Adjusting Copy Image Density”

- On
- Off

Note

Default: *On*

❖ Density Priority

Specified one of seven density levels as the image density.

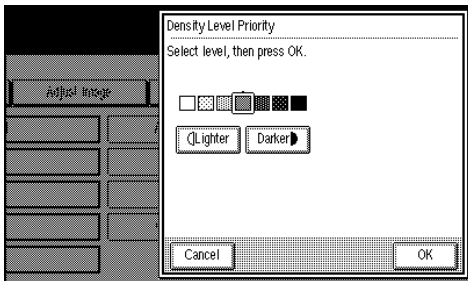

Note

Default: *Center*

❖ Auto Paper Select Priority

Specifies whether Auto Paper Select should be used after the machine is turned on, after Auto Reset, or after the **【Clear Modes/Energy Saver】** key has been pressed, or not. See P.42 “Selecting Copy Paper”

- On
- Off

Note

Default: *On*

❖ Paper Roll Priority

Specifies the default paper roll to be used after the machine is turned on, after Auto Reset, or after the **【Clear Modes/Energy Saver】** key has been pressed.

- Paper Roll 1
- Paper Roll 2
- Paper Roll 3 (option)

Note

Default: *Paper Roll 1*

❖ Print Start Trigger

Specifies whether all the originals should be scanned first, or not.

To scan the originals first and then copy when the **[Start]** key is pressed, press the **[Press Start Key]** key, To start copying automatically after the originals have been scanned, press the **[Set Original]** key.

- Press Start Key
- Set Original

 Note

- Default: *Set Original*

❖ Original Size Auto Detect

Specifies whether to detect the size of the original or not.

If On is selected, the machine automatically detects the size of the original. If Off is selected, the machine ignores the original size and assumes it is the largest size original. For example, to copy a an original 841mm wide, or JIS B series size or other custom size original, set this setting to Off to scan the original at the maximum width of 914mm. (In this case, be sure to select a paper size larger than the original when making the copy. (When enlarging, be sure to select a size larger than the original size × reproduction ratio.))

- Off
- On

 Note

- Default: *On*
- When using 30" width original, set this setting to Off.

General Features 2/2

❖ Memory Status Display

Specifies how the amount of remaining memory should be displayed. If you select **[Page]**, it is displayed as a number of A1(D) pages.

- Percentage
- Page

 Note

- Default: *Page*

❖ Maximum Copy Quantity

Specifies the maximum number of copies that can be made with the Repeat Copy function. See P.34 "Repeat Copy"

 Note

- Default: *99 copies*
- The value can be set from 0 to 99 copies.

❖ Noise Reduction

Specifies the noise (small specks of dirt or dust on the image) reduction level for each of the original types (Text, Text/Photo, Pale, Special Original.)

If you select **[Off]**, small scratches and specks on the original will not be removed.

- Off
- Low
- Medium
- High

 Note

Default: *Off*

❖ Original Mode Quality Level

Adjusts the finish for each original type.

- Normal
- Special

 Note

Default: *Normal*

When select **[Special]**: Your service representative will set this to a value that matches your requirements. For details consult your service representative.

❖ Manual Image Density Level

Specifies the copy image density for each original type.

- Lighter
- Normal
- Darker

 Note

Default: *Normal*

❖ Sort Copy Setting

Specifies whether all the originals should be scanned before starting copying, when using the Sort function. Or whether copying should start while originals are still being scanned. See P.51 “Sort/Rotate Sort”

If "Rear" is selected for the copy output when using the Sort function, even if **[Copy after Each Scan]** is selected, copying starts after all the originals have been scanned.

- Copy after All Scans
- Copy after Each Scan

 Note

Default: *Copy after All Scans*

❖ **Sample Copy Priority**

Specifies the default dimensions to be used for the Sample Copy function. See P.56 “Sample Copy”

 **Note**

- Default: 0
- The value can be set from 0 to 250 mm (9”).

❖ **Partial Copy Priority**

Specifies the default dimensions to be used for the start point (Y1) and end point (Y2) in the Partial Copy function. See P.57 “Partial Copy”

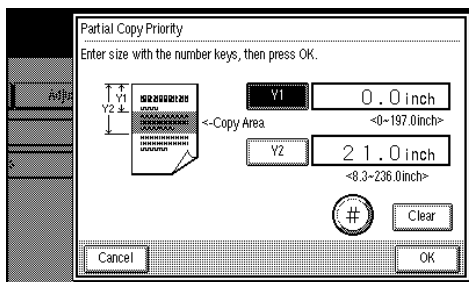

4

 **Note**

- Default:
 - Y1: 0 (0.0")
 - Y2: 210 mm (8.3")
- Y1 can be set from 0 to 5000 mm (0" to 197.0").
- Y2 can be set from 210 to 6000 mm (8.3" to 236.0").

❖ **Feed Start Trigger**

Specifies how copying starts.

If you select **[Set Original]**, copy starts automatically, if you select **[Press Start Key]** then copying starts after you press the **[Start]** key.

- Set Original
- Press Start Key

 **Note**

- Default: *Set Original*

Reproduction Ratio

❖ User Reproduction Ratio

You can store up to three reproduction ratios, in addition to those in the Pre-set Ratio function.

Enter the desired reproduction ratio with the number keys.

Note

- Default: 100 %
- Use the **[.]** key to enter a decimal point.
 - 25.0% – 400.0%

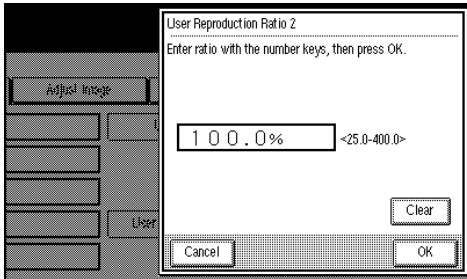

4

❖ Preset Reduce/Enlarge Priority

When **[Reduce/Enlarge]** key is pressed, the selected reproduction ratio is used as the priority ratio.

The selected user reproduction ratio will also have priority when the **[Reduce/Enlarge]** key is pressed.

Note

- Default:
 - Metric version: 71%
 - Inch version (Engineering): 65%
 - Inch version (Architecture): 67%

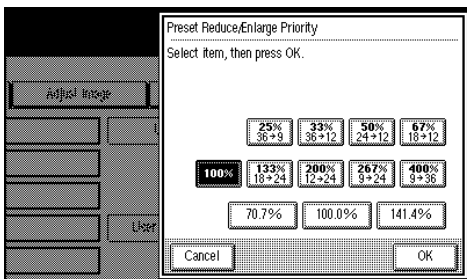

❖ **Shortcut Reduce/Enlarge**

You can specify a frequently used reproduction ratio to appear on the basic screen.

 **Note**

Default:

- Metric version: 71%
- Inch version (Engineering): 65%
- Inch version (Architecture): 67%

❖ **User Auto Reduce/Enlarge**

Specifies the original and copy sizes to be displayed when the [User Auto R/E] key is pressed. See P.44 "User Auto Reduce/Enlarge"
Select the copy size to use with the original size.

4

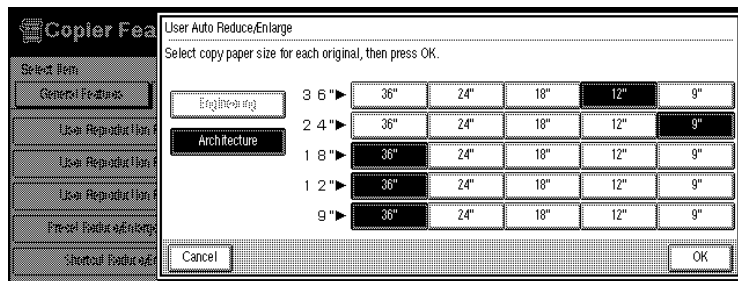

 **Note**

If you have selected a setting for A0(E) size paper in Auto Reduce/Enlarge, you cannot select "Original orientation" (grayed out). When you cannot select "Original orientation" (grayed out), select the original size and copy size for Horizontal in this setting.

❖ **User Auto R/E Original Size Detect**

Specifies whether an original should be processed as a vertical or horizontal original when [User Auto R/E] is selected. See P.44 "User Auto Reduce/Enlarge"

- Original Orientation:
- Original Orientation:

 **Note**

Default: Original Orientation

Adjust Image

❖ Margin Adjustment Priority

Specifies the default setting for the size of the margin.

You can set the size for the top and bottom margin. See P.68 “Margin Adjustment”

Note

- Default:
 - Metric version: 20 mm
 - Inch version: 0.8"

❖ Shift Image Area Priority

Specifies the default setting for the Shift function. Use the arrow keys to set the shift direction and distance. See P.70 “Shift”

Note

- Default:
 - Metric version: 20 mm
 - Inch version: 0.8"

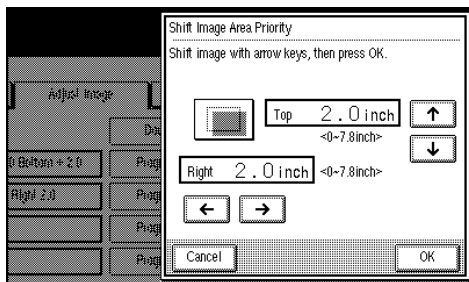

❖ Border Erase Width Priority

Specifies the default setting for the Border Erase function. See P.72 “Border Erase”

Use the [+] or [-] keys to make the setting.

Note

- Default:
 - Metric version: 10 mm
 - Inch version: 0.9"

❖ **Image Repeat Separation Line**

Specifies the type of line to use for the separation line. See P.78 “*Image Repeat*”

- None
- Solid
- Broken A
- Broken B
- Crop Marks

 **Note**

Default: *None*

❖ **Double Copies Separation Line**

Specifies whether to use a separation line, or not, for the Double Copies function. See P.77 “*Double Copies*”

The separation line will be a dotted line.

- None
- Separation Line

 **Note**

Default: *Separation Line*

❖ **Program/Delete, Overlay Format**

Stores a format image (background image) for use with the Format Overlay function.

You can store up to four formats.

See P.83 “*Format Overlay*”, P.84 “*Program/Delete, Overlay Format*”

Stamp 1/2

❖ **Preset Stamp Priority**

Specifies the default user stamp to be selected for the Preset Stamp function. See P.88 “*Preset Stamp*”

- COPY
- URGENT
- PRIORITY
- For Your Info
- PRELIMINARY
- For Internal Use Only
- CONFIDENTIAL

 **Note**

Default: *COPY*

❖ Preset Stamp Format Priority

Specifies the size, density, print direction and print position for each of the preset stamps (COPY, URGENT, PRIORITY, For Your Info., PRELIMINARY, For Internal Use Only, CONFIDENTIAL). You can make separate settings for both horizontal and vertical. See P.88 "Preset Stamp"

- Size (1X, 2X, 4X, 8X)
- Density (Normal, Light, Very Light)
- Orientation (Horiz., Vert.)
- Position

Note

Default:

- Size: 1X
- Density: Normal
- Orientation: Horiz.
- Position: Bottom Right

4

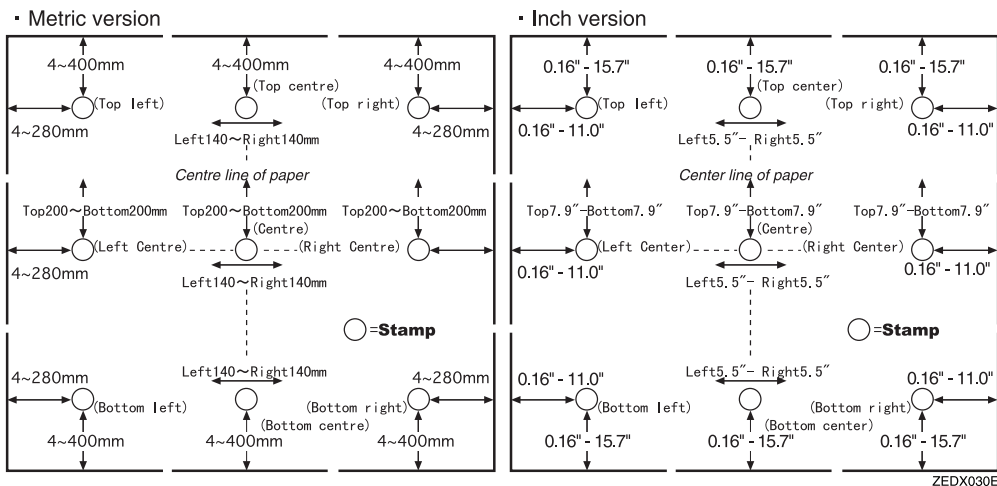

❖ Preset Stamp Position Adjustment

Specifies the print position on the copies for each of the preset stamps. Enter the settings for stamp position with the **[+]**/**[-]** keys or the number keys.

Note

Default:

- **[From Left][From Right][From Top][From Bottom]:**
 - Metric version: 24 mm
 - Inch version: 0.9"
- **[From Horiz. Center]:**
 - Metric version: 0 mm
 - Inch version: 0.0"

❖ **Date Stamp Format Priority**

Specifies the format and other conditions to be used for the Date Stamp function. See P.94 “Date Stamp”

You can specify the format to be used for the date stamp and its orientation and position.

- Date format
 - MM/DD/YYYY
 - DD/MM/YYYY
 - YYYY.MM.DD
 - MM.DD.YYYY
 - DD.MM.YYYY
 - DD.JUN.YYYY
- Orientation
- Position

4

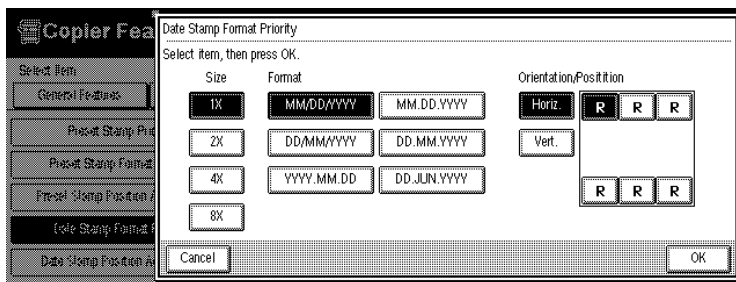

Note

- ❑ Default:
 - Date Format: *MM/DD/YYYY*
 - Orientation: *Horiz.*
 - Position: *Top Left*

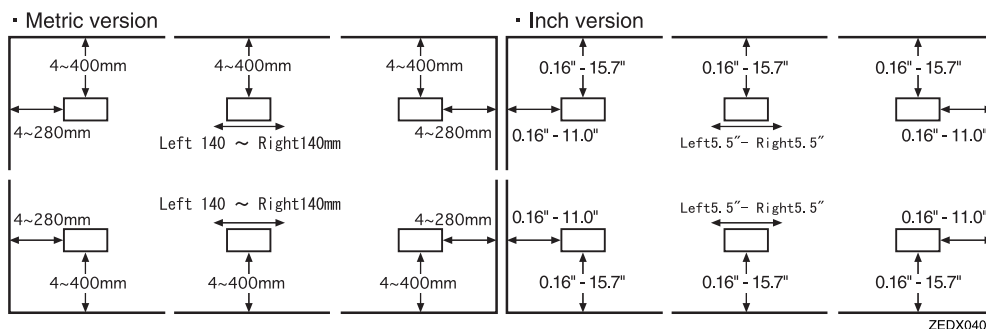

❖ Date Stamp Position Adjustment

Specifies the print position on the copies for the date stamp.

Enter the settings for stamp position with the **[+]****[-]** keys or the number keys.

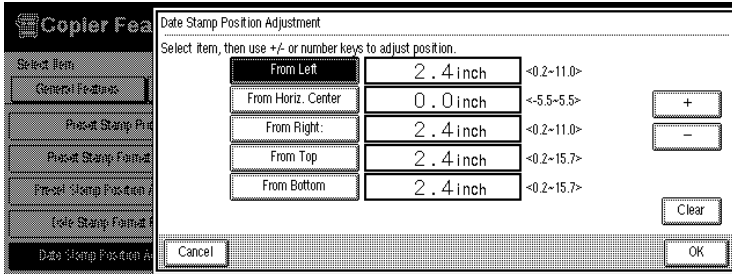

Note

□ Default:

- **[From Left][From Right][From Top][From Bottom]:**
 - Metric version: 24 mm
 - Inch version: 0.9"
- **[From Horiz. Center]:**
 - Metric version: 0 mm
 - Inch version: 0.0"

4

❖ Background Numbering Format

Specifies the format and other conditions to be used for the Background Numbering function. See P.86 "Background Numbering"
You can specify the print size and density.

- Size (1X, 2X, 4X, 8X)
- Density (Light, Normal, Dark, Very Dark)

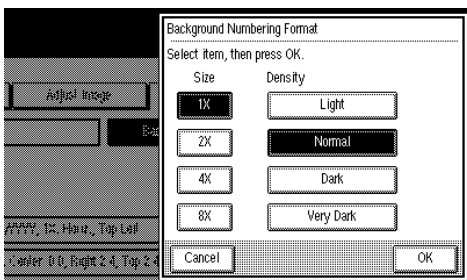

Note

□ Default:

- Size: 1X
- Density: Normal

Stamp 2/2

❖ User Stamp Format Priority

Specifies the density, print direction and print size to be used for user stamps. You can set separate settings for horizontal and vertical. See P.90 "User Stamp"

- Density (Normal, Light, Very Light)
- Orientation (Horiz., Vert)
- Position

Note

Default:

- Density: Normal
- Position: Horiz
- Position: Bottom Right

4

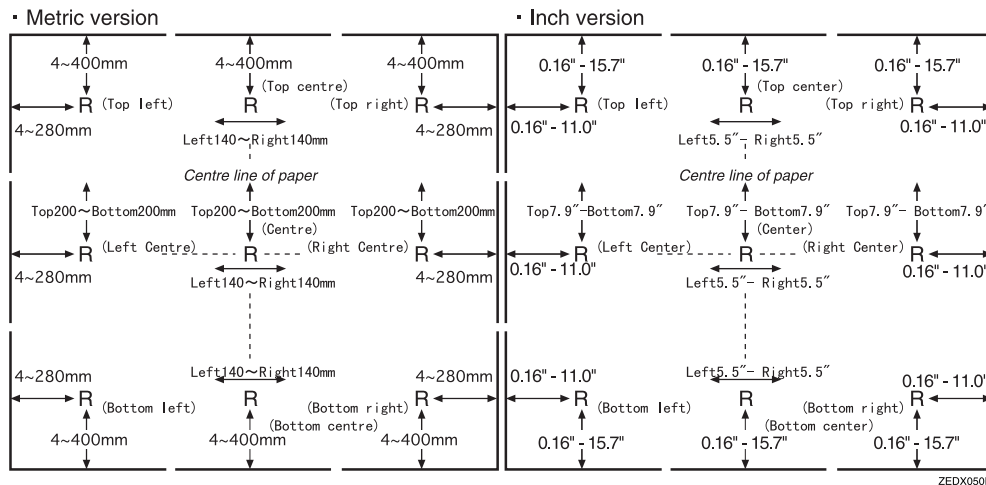

❖ User Stamp Position Adjustment

Specifies the print position on the copies for user stamps.

Enter the settings for stamp position with the **[+]**/**[-]** keys or the number keys.

Note

Default:

- **[From Left][From Right][From Top][From Bottom]:**
 - Metric version: 24 mm
 - Inch version: 0.9"
- **[From Horiz. Center]:**
 - Metric version: 0 mm
 - Inch version: 0.0"

❖ **Program/Delete, User Stamp**

You can store, change, or delete a design of your choice as a user stamp.

You can store up to four user stamps.

See P.90 "User Stamp", P.91 "Program/Delete, User Stamp"

❖ **Page Numbering Format**

Specifies the conditions to be used for the Page Numbering function. See P.96 "Page Numbering"

You can specify the format to be used for the page number and its orientation and position.

- Format
 - 1, 2...
 - p1, p2...
 - 1/5, 2/5...
 - -1-, -2-...
 - p.1, p.2...
- Orientation (Horiz., Vert)
- Position

 **Note**

Default:

- Format: 1,2,3.....
- Orientation: *Horiz*
- Position: *Top Left*

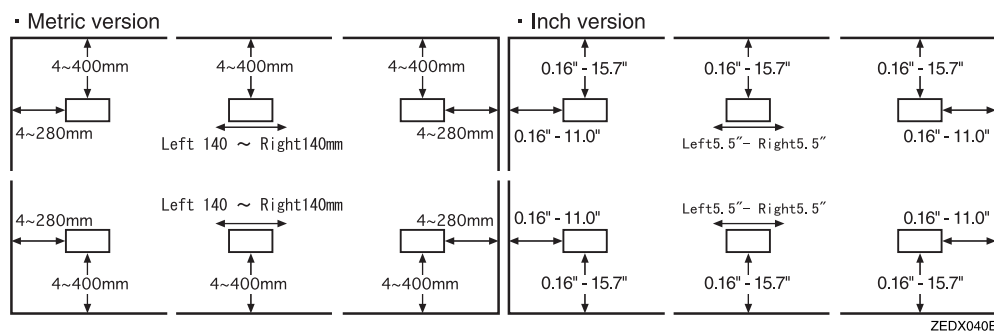

❖ **Page Numbering Position Adjustment**

Specifies the print position on the copies for the page number.

Enter the settings for numbering position with the **[+]****[-]** keys or the number keys.

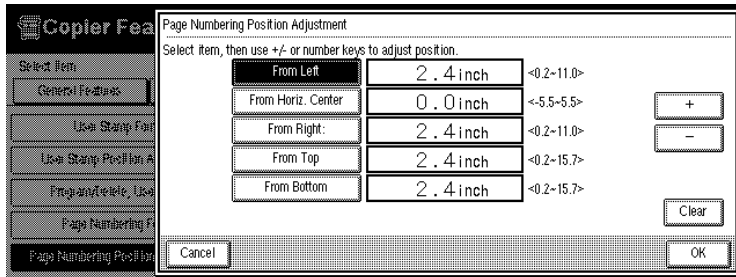

4

Note

Default:

- **[From Left][From Right][From Top][From Bottom]:**
 - Metric version: 24 mm
 - Inch version: 0.9"
- **[From Horiz. Center]:**
 - Metric version: 0 mm
 - Inch version: 0.0"

Key Operator Tools

When a key operator code has already been entered, you cannot begin manager setting unless you enter the key operator code(up to 8 digit).

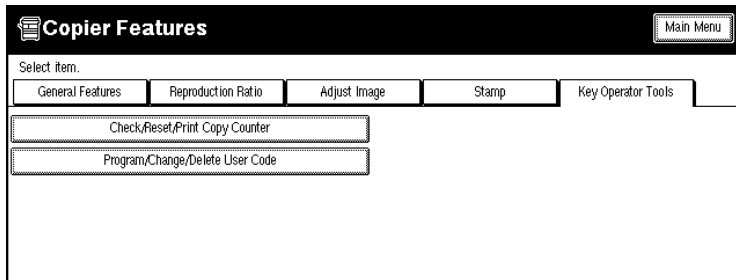

❖ Check/Reset/Print, Copy Counter

You can check or print the number of copies made under each user code. You can also reset each user code's counter to 0.

 Note

- Print Counter List
 - Press the **[Print Counter List]** key.
- Reset Counter.
 - Press the **[Reset Counter]** key.
- Reset All Counters
 - Press the **[Reset All Counters]** key.

❖ Program/Change/Delete, User Code

You can register, change, or delete user codes (8 digits or less). You can store up to 100 user codes.

4

 Note

- Program
 - You can register user codes.
Press the **[Program]** key, and then enter the user code with the number keys.
- Change
 - You can change user codes.
Press the **[Change]** key after selecting the user code.
- Delete User Code
 - You can delete user codes.
Press the **[Delete User Code]** key after selecting the user code you want to delete.
- Delete All User Codes
 - You can delete all user codes.
Press the **[Delete All User Codes]** key.

5. Remarks

Do's and Don'ts

CAUTION:

- *Unplug the power cord from the wall outlet before you move the equipment. While moving the equipment, you should take care that the power cord will not be damaged under the equipment.*

Important

- Only disconnect the power cord after checking that all copies are finished.
 - Do not touch areas on or around the fusing unit. These areas get hot.
 - After making copies continuously, the exposure glass may feel warm to the touch. This is not a malfunction.
 - Make sure the machine is well ventilated when in use. If the machine is operated for a long time in a poorly ventilated location, it may begin to smell. We recommend that you use the machine in a well ventilated room to ensure you maintain the operating conditions.
 - You might feel warm around the ventilation hole. This is caused by exhaust air, and not a malfunction.
 - Do not turn off the operation switch while copying or printing. When turning off the operation switch, make sure that copying or printing is completed.
 - Do not open the covers of machine while copying or printing. If you do, misfeeds might occur.
 - Do not drop staples, paper clips, or other object in to the machine.
 - Do not stand or sit on the machine.
 - Do not leave the paper path section open for more than 10 minutes.
 - Do not touch the photosensitive conductor. If you touch it by accident, wipe it gently with a soft cloth.
 - If you will not be using the machine for a long time, remove the paper from the paper roll tray and place it in its storage bag.
 - The machine might fail to produce good copy images if there should occur condensation inside caused by temperature change. To prevent such trouble, this machine has an anti-condensation function. Even after the main power switch is in the stand-by position, the anti-condensation heater is active, thus keeping the machine body slightly warm.
 - The machine has a Anti-humidity function. Even when the main power switch is in the Off position, the Anti-humidity heater is active if it is turned on.
 - Do not move the machine while copying or printing.

Remarks

- Be sure to take a note of your machine settings. If you operate the machine improperly or a failure occurs in the machine, your machine settings might be lost.
- Supplier shall not be liable for any loss or damages resulting from a failure on the machine, loss of machine settings, and use of the machine.

Where To Put Your Machine

Machine Environment

Your machine's location should be carefully chosen because environmental conditions greatly affect its performance.

Optimum environmental conditions

⚠ CAUTION:

- *Keep the equipment away from humidity and dust. Otherwise a fire or an electric shock might occur.*
- *Do not place the equipment on an unstable or tilted surface. If it topples over, it could cause injury.*

⚠ CAUTION:

- *If you use the equipment in a confined space, make sure there is a continuous air turnover.*

- Temperature: 10 – 32°C (50 – 89.6°F)(humidity to be 54% at 32°C, 89.6°F)
- Humidity: 15 – 80% (temperature to be 27°C, 80.6°F at 80%)
- A strong and level base.
- The machine must be level within 5mm, 0.2" both front to rear and left to right.
- To avoid possible buildup of ozone, be sure to locate this machine in a large well ventilated room that has an air turnover of more than 30 m³/hr/person.

Environments to avoid

- Locations exposed to direct sunlight or strong light (more than 1,500 lux).
- Locations directly exposed to cool air from an air conditioner or heated air from a heater. (Sudden temperature changes might cause condensation within the machine.)
- Locations close to such machines generating ammonia such as diazo copy machines.
- Places where the machine might be subjected to frequent strong vibration.
- Dusty areas.
- Areas with corrosive gases.

Remarks

Access To Machine

Place the machine near the power source, providing clearance as shown.

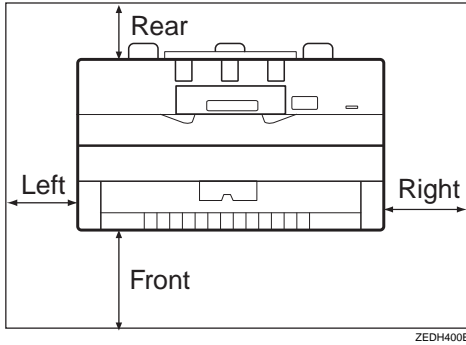

5

	Standard setting
Front	more than 100cm (40")
Rear	more than 70cm (27.6")
Left	more than 40cm (15.8")
Right	more than 45cm (17.8")
Upper	more than 45cm (17.8")

 **Note**

- For the required space when options are installed, please contact your service representative.

Power Connection

⚠ WARNING:

- **Only connect the machine to the power source described on the inside front cover of this manual. Connect the power cord directly into a wall outlet and do not use an extension cord.**
- **Do not damage, break or make any modifications to the power cord. Do not place heavy objects on it. Do not pull it hard nor bend it more than necessary. These actions could cause an electric shock or fire.**

⚠ CAUTION:

- *Unplug the power cord from the wall outlet before you move the equipment. While moving the equipment, you should take care that the power cord will not be damaged under the equipment.*

⚠ CAUTION:

- *When you disconnect the power plug from the wall outlet, always pull the plug (not the cable).*

- When the main switch is in the Stand-by positions, the optional anti-condensation heaters are on. In case of emergency, unplug the machine's power cord.
- When you unplug the power cord, the anti-condensation heaters turn off.
- Make sure that the plug is firmly inserted in the outlet.
- Voltage must not fluctuate more than 10%.
- The socket-outlet shall be installed near the equipment and shall be easily accessible.

5

Disposal

Contact your service representative if you want to dispose of the machine.

Maintaining Your Machine

If the exposure glass or feed rollers are dirty, you will not be able to make clear copies. Clean them when they become dirty.

❖ Cleaning the machine

Wipe the machine with a soft dry cloth. If this does not remove the dirt, wipe the machine with a damp, tightly wrung, cloth. If a damp cloth still does not remove the dirt, try using a mild detergent. Wipe the machine with a dry cloth to remove the moisture, after using a damp cloth.

5

⚠ Important

- Do not use chemical cleaner or organic solvent, such as thinner or benzene. If they get into the machine or melt plastic parts, a failure might occur.
- Do not clean parts other than those specified in this manual. Such parts should be cleaned by your service representative.

Cleaning inside the Original Cover

If you open the original cover, you can access the exposure glass and original feed mechanism.

- 1** Lift the release lever on the original cover and open the cover while holding it on both sides.

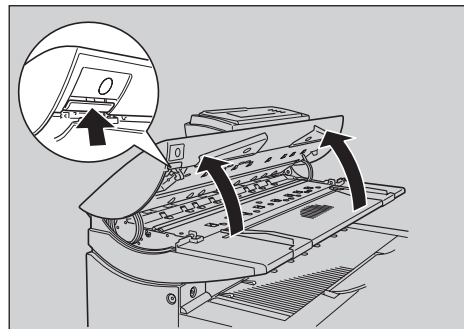

ZEDH210E

Cleaning the exposure glass

- 1** Wipe the exposure glass with a soft, damp cloth.

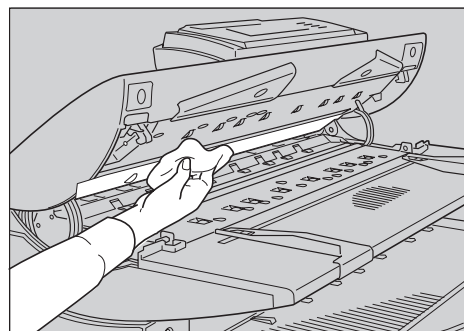

ZEDH220E

Cleaning the feed roller

- 1 Wipe the feed roller with a soft, dry cloth while turning the roller.

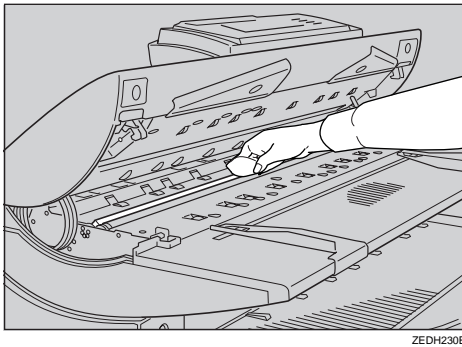

Cleaning the original feed guide

- 1 Wipe the original feed guides at the top and bottom with a soft, dry cloth.

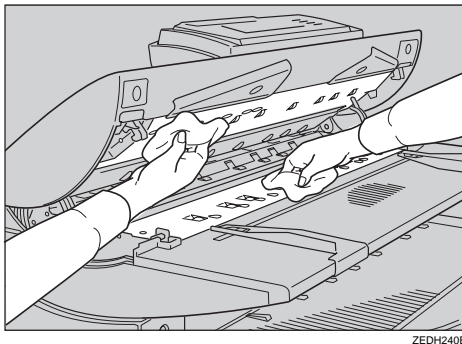

Note

- If there is paper dust or threads inside, remove them.

- 2 Close the original cover gently.

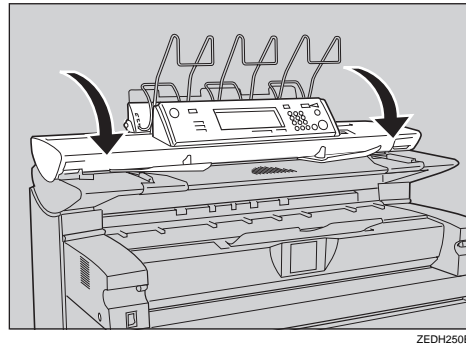

Cleaning The Paper Path Section

Cleans toner powder that may have collected on the imaging area.

5

- 1 Lift the release levers on either side and open the paper path section.

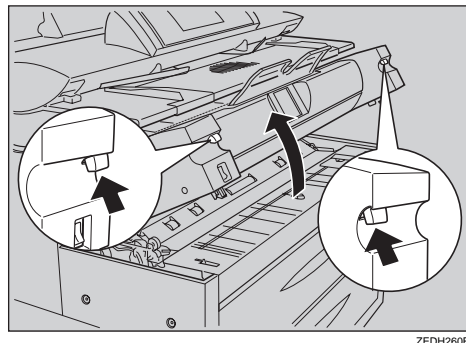

Important

- Do not leave the paper path section open for more than 10 minutes.

Remarks

2 Wipe it with a soft, dry cloth.

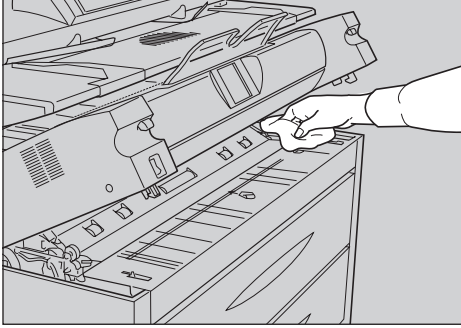

ZEDH270E

3 Close the paper path section cover gently.

5

6. Specification

Mainframe

- ❖ **Configuration:**
Console
- ❖ **Fusing:**
Digital dry electrostatic transfer system
- ❖ **Originals:**
Sheet
- ❖ **Original size (W × L):**
 - Metric version: 210 × 182mm-914 × 6000mm
 - Inch version: 8¹/₂" × 9"-36" × 236"
- ❖ **Copy size (W × L):**
 - Metric version:
A0 -A4
Roll paper: 210 × 210mm-914 × 6000mm
Bypass tray: 210 × 182mm-914 × 2000mm
 - Inch version:
E -A
Roll paper: 8¹/₂" × 8¹/₂" -36" × 236"
Bypass tray: 8¹/₂" × 9"-36" × 78"
- ❖ **Reproduction ratio:**
 - Metric version:
Full-size: 100%
Reduce: 25.0%, 35.4%, 50.0%, 70.7%
Enlarge: 141.4%, 200.0%, 282.8%, 400.0%
Zoom: 25.0-200.0% (0.1% step)
Zoom: 200.0-400.0% (0.2% step)
 - Inch version (Engineering):
Full-size: 100%
Reduce: 25.0%, 32.0%, 50.0%, 65.0%
Enlarge: 129.0%, 200.0%, 259.0%, 400.0%
Zoom: 25.0-200.0% (0.1% step)
Zoom: 200.0-400.0% (0.2% step)

- Inch version (Architecture):
 Full-size: 100%
 Reduce: 25.0%, 33.0%, 50.0%, 67.0%
 Enlarge: 133.0%, 200.0%, 267.0%, 400.0%
 Zoom: 25.0-200.0% (0.1% step)
 Zoom: 200.0-400.0% (0.2% step)

❖ **Copying speed (full-size copying):**
 7 copies/minute (A1(D)☐) (3.54 inch per second)

❖ **Warm-up time:**
 Less than 2 minutes (20°C)

- ❖ **First copy time:**
- Metric version:
 When selected upper tray: 18 seconds (A1☐), 25 seconds(A0☐)
 - Inch version:
 When selected upper tray: 18.5 seconds (D☐), 25.4 seconds(E☐)

❖ **Repeat copy:**

- Metric version:
 - Mainframe only

Width	Length
914/880mm	Up to 1,219mm
841mm	Up to 1,325mm
594mm	Up to 1,875mm
420mm	Up to 2,652mm (Transportation distance:2,000mm)
297mm	Up to 2,751mm (Transportation distance:2,000mm)
When deleting a copy size: Up to 1,219mm	

- Optional HDD installed
 6 m (any width)

- Inch version (Engineering):

- Mainframe only

Width	Length
34"	Up to 50.8"
22"	Up to 78.5"
17"	Up to 101.6"
11"	Up to 157"
8 ¹ / ₂ "	Up to 203.2"
When deleting a copy size: Up to 50.8"	

- Optional HDD installed
6 m (any width)

- Inch version (Architecture):

- Mainframe only

Width	Length
36" (30")	Up to 48"
24"	Up to 72"
18"	Up to 96"
12"	Up to 144"
9"	Up to 192"
When deleting a copy size: Up to 48"	

- Optional HDD installed
6 m (any width)

- ❖ **Non-reproduction area:**

- Metric version:

- Top: 8mm
 - Bottom: 10mm
 - Left and Right 2 ± 2mm (less than 6mm on either side)

- Inch version:

- Top: 0.32"
 - Bottom: 0.39"
 - Left and Right 0.08" ± 0.08" (less than 0.24" on either side)

- ❖ **Continuous copying count:**

99 copies

- ❖ **Copy paper capacity:**

2 roll unit/bypass tray

❖ **Power source:**

- Metric version
220-240V, 50Hz/60Hz, 10A
- Inch version
120V, 60Hz, 20A

❖ **Dimensions (W × D × H):**

1,250 × 748 × 1,200mm, 49.2" × 29.4" × 47.2"

❖ **Weight:**

Approx. 225kg, 496lb

❖ **Original scanning:**

Original feed image scanning over a fixed contact image sensor

❖ **Original scanning pivot:**

Center

❖ **Light source:**

LED

6

❖ **Scanning resolution:**

600dpi

❖ **Scanning gradation:**

256 values

❖ **Printing gradation:**

4 values

❖ **Printing resolution:**

600dpi

❖ **Photo conductor type:**

OPC

❖ **Development:**

Dry two-component magnetic brush development system

❖ **Fusing:**

Hot roller

❖ **Power consumption:**

	Metric version	Inch version
Warm-up	1.6 kw	1.7 kw
Ready (Anti-humidity heater = OFF)	0.2 kw	0.2 kw
During printing	1.5 kwh	1.4 kwh
Maximum	1.8 kw	1.7 kw

❖ **Noise Emission ^{*1}:**

Sound Power Level:

Stand-by	Less than 50.6 dB (A)
Copying	Less than 65.7 dB (A)

Sound Pressure Level ^{*2}:

Stand-by	Less than 38.0 dB (A)
Copying	Less than 54.7 dB (A)

^{*1} The above measurements are made in accordance with ISO 7779 which are the actual value.

^{*2} It is measured at the position of the operator.

Options

❖ **2nd Roll Tray TypeA**

Adds the lower tray (paper roll 3).

❖ **Roll Holder Unit TypeA**

When using different sizes of roll paper, use the roll holder to quickly change the paper rolls.

❖ **Original Tray TypeG**

Attach this to the rear of the machine to store large quantities of originals.

❖ **Stamp Board TypeA**

Adds the print capability required for the Background Numbering, Preset Stamp, User Stamp, Date Stamp, User Stamp Repeat, and Page Numbering functions.

❖ **Hard Disk Drive Option Type 470**

Allows you to increase the copy functions, like the following:

- Repeat Copy (longer than A0(E))
- Stamp function (registered stamp board)
- Sort/Rotate Sort (50 sheets or more)
- Restart Copy (longer than A0(E))
- Format Overlay
- Sample Copy (longer than A0(E))

Settings Record Sheet

❖ Program Record Sheet

Program No.	Original name	Function 1	Function 2	Function 3	Function 4	Function 5
1						
2						
3						
4						
5						
6						
7						
8						
9						
10						
11						
12						
13						
14						
15						
16						
17						
18						
19						
20						

6

Please make a copy of this sheet and use it to keep a record of your program settings.

❖ **Stored Format Record Sheet**

6

Format No.	Original name	Note	Date
1			
2			
3			
4			
5			
6			
7			
8			
9			
10			

Please make a copy of this sheet and use it to keep a record of your format settings.

◆ **User Stamp Record Sheet**

Record No.	Corporation/section/project...etc	Stamp image	Date	
1				
2				
3				
4				

Please make a copy of this sheet and use it to keep a record of your user stamps.

Magnification Ratio Chart

❖ Metric version (A series)

		Copy size				
		A0	A1	A2	A3	A4
Original size	A0	100.0	70.7	50.0	35.4	25.0
	A1	141.4	100.0	70.7	50.0	35.4
	A2	200.0	141.4	100.0	70.7	50.0
	A3	282.8	200.0	141.4	100.0	70.7
	A4	400.0	282.8	200.0	141.4	100.0

❖ Inch version (Engineering)

		Copy size				
		E	D	C	B	A
Original size	E	100.0	65.7	50.0	32.0	25.0
	D	129.0	100.0	65.0	50.0	32.0
	C	200.0	129.0	100.0	65.0	50.0
	B	259.0	200.0	129.0	100.0	65.0
	A	400.0	259.0	200.0	129.0	100.0

❖ Inch version (Architecture)

		Copy size				
		E	D	C	B	A
Original size	E	100.0	67.0	50.0	33.0	25.0
	D	133.0	100.0	67.0	50.0	33.0
	C	200.0	133.0	100.0	67.0	50.0
	B	267.0	200.0	133.0	100.0	67.0
	A	400.0	267.0	200.0	133.0	100.0

Measure Chart

❖ Metric version (A series)

	Width × Length
A0	841 × 1,189 mm
A1	594 × 841 mm
A2	420 × 594 mm
A3	297 × 420 mm
A4	210 × 297 mm

❖ Inch version (Engineering)

	Width × Length
E	34" × 44"
D	22" × 34"
C	17" × 22"
B	11" × 17"
A	8 ¹ / ₂ " × 11"

❖ Inch version (Architecture)

	Width × Length
E	36" × 48"
D	24" × 36"
C	18" × 24"
B	12" × 18"
A	9" × 12"

INDEX

A

Accessing The User Tools (Copier Features), 123
Additional Copy, 36
Adjust Image, 133
Adjusting Copy Image Density, 41
Anti-humidity Heater Switch, 12
Auto Image Density Priority, 127
Auto Off, 30
Auto Paper Select Priority, 127
Auto Reduce/Enlarge, 43
Auto Reset, 30
Auto Start, 55

B

Background Numbering, 86
Background Numbering Format, 137
Basic Functions, 40
Basic Procedure, 28
BASICS, 11
Before Copying, 21
Border Erase, 72
Border Erase Width Priority, 133

C

Changing The Roll Paper Size, 111
Chart of Scan Sizes for Each Function, 101
Check/Reset/Print, Copy Counter, 141
Cleaning inside the Original Cover, 148
Cleaning The Paper Path Section, 149
 Loading Roll Paper, 113
Combination Chart, 98
Copier Reset Timer, 126
Copying, 21
Copying from the Bypass Tray, 46
Copy Paper, 16

D

 Adding Toner, 115
Date Stamp, 94
Date Stamp Format Priority, 136
Date Stamp Position Adjustment, 137
Delete Inside, 74
Delete Outside, 76
Deleting a Program, 54
Density Priority, 127
Directional Magnification (%), 64
Directional Size Magnification (inch), 66
Displays And Key Operations, 8
Disposal, 147
Do's and Don'ts, 143
Double Copies, 77
Double Copies Separation Line, 134

E

Energy Saver Mode, 55

F

Feed Start Trigger, 130
Fine Magnification, 61
Format Overlay, 83

G

General Features 1/2, 126
General Features 2/2, 128
Guide to Components, 1
Guide To Option Components, vi

H

Handling, 20

I

If You Cannot Make Clear Copies, 106
If You Cannot Make Copies As
You Want, 109
If Your Machine Does Not Operate As
You Want, 103
Image Overlay, 81
Image Overlay Limitations, 82
Image Repeat, 78
Image Repeat Separation Line, 134
Initial Mode Set, 126
Interrupt Copy, 39

J

Job Preset, 37

K

Key Names, vi
Key Operator Tools, 140

M

Machine Environment, 145
Magnification Ratio Chart, 160
Mainframe, 151
Maintaining Your Machine, 148
Manual Image Density Level, 129
Margin Adjustment, 68
Margin Adjustment Priority, 133
Maximum Copy Quantity, 128
Measure Chart, 161
Memory Status Display, 128
Message, 103
Mirror Image, 80
Missing Image Area, 15

N

Noise Reduction, 129

O

Operation Panel, 6
Options, 5, 156
Original Counter/Reset, 29
Original Misfeeds, 117
Original Mode Priority, 126
Original Mode Quality Level, 129
Originals, 13
Other Functions, 55

P

Page Numbering Format, 139
Page Numbering Position Adjustment, 140
Panel Screen, 8
Paper Misfeeds, 118
Paper Roll Priority, 127
Partial Copy Priority, 130
Positive/Negative, 79
Power Connection, 147
Preset Cut, 49
Preset Reduce/Enlarge, 58
Preset Reduce/Enlarge Priority, 131
Preset Stamp, 88
Preset Stamp Format Priority, 135
Preset Stamp Position Adjustment, 135
Preset Stamp Priority, 134
Print Start Trigger, 128
Program, 53
Program/Change/Delete, User Code, 141
Program/Delete, Overlay Format, 84
Program/Delete, User Stamp, 91, 139

R

Recalling a Program, 54
Recommended Size and Type, 16
Remarks, 143
Repeat Copy, 34
Reproduction Ratio, 131
Restart Copy, 35

S

Safety Information, i
Sample Copy, 56
Sample Copy Priority, 130
Screen, 105
Selecting Copy Paper, 42
Selecting Original Type Setting, 40
Setting Carrier Sheet, 32
Setting Originals, 31
Settings Record Sheet, 157
Settings You Can Change with the User Tools, 126
Setting the Length of Copy Paper Cut, 48
Shift, 70
Shift Image Area Priority, 133
Shortcut Reduce/Enlarge, 132
Size Magnification, 63
Sizes and Weights, 13
Sort, 51
Sort Copy Setting, 129
Specification, 151
Stamp 1/2, 134
Stamp 2/2, 138
Starting The Machine, 11
Storage, 20
Storing Your Settings, 53
Synchro Cut, 48

T

Terms, vi
Toner, 20
Troubleshooting, 103
Turning Off the Main Power, 12
Turning Off the Power, 12
Turning On the Main Power, 11
Turning On the Power, 11

U

User Auto Reduce/Enlarge, 44, 132
User Auto R/E Original Size Detect, 132
User Codes, 55
User Reproduction Ratio, 131
User Stamp, 90
User Stamp Format Priority, 138
User Stamp Position Adjustment, 138
User Stamp Repeat, 87
User Tools (Copier Features), 123
User Tools Menu (Copier Features), 125

V

Variable Cut, 50

W

Warnings and Precautions, iii
What You Can Do With This Machine (Copy Mode), viii
Where To Put Your Machine, 145

X

 Clearing Misfeeds, 117

Z

Zoom, 59